

SERIES AP

DIAPHRAGM OPERATED PRESSURE SWITCH

Visible Set point Adjustment, Compact

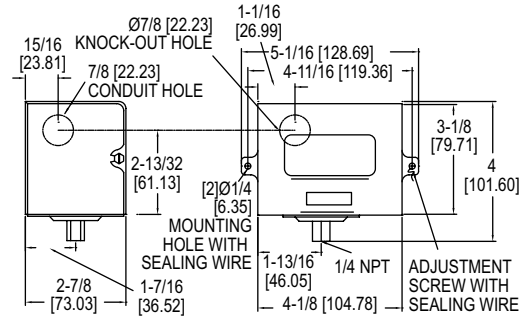

Reliable and convenient, the **Series AP Diaphragm Operated Pressure Switch** is a compact switch for instrument air or other low pressure applications. Visible set point and external adjustment add convenience. Used on air, non-corrosive gas or liquid service compatible with wetted parts. Units are available in weather-proof and explosion-proof housing.

BENEFITS/FEATURES

- Explosion-proof and weatherproof housing provides device protection for outdoor use or harsh environment operation
- External switch set point adjustment reduces set-up time

APPLICATIONS

- Low pressure applications
- Instrument air

SPECIFICATIONS

Wetted Materials: Nylon reinforced Buna-N and steel. PTFE and 316 SS optional.

Temperature Limits: -30 to 150°F (-35 to 66°C).

Pressure Limit: See model chart.

Enclosure Rating: General purpose. Weatherproof and explosion-proof optional.

Switch Type: SPDT mercury switch or SPDT snap switch. Other switch types available.

Electrical Rating: Mercury switch: 4 A @ 120 VAC/DC, 2 A @ 240 VAC/DC; Snap switch: 15 A @ 120 VAC, 8 A @ 240 VAC, 0.5 A @ 120 VDC, 0.25 A @ 240 VDC.

Electrical Connections: Screw terminal.

Conduit Connection: 7/8" (22.23 mm) hole for 1/2" (12.7 mm) conduit hub.

Process Connection: 1/4" female NPT.

Mounting Orientation: Vertical for mercury switch models, any position for snap switch models.

Set Point Adjustment: External screw.

Weight: General purpose: 2 lb (0.9 kg).

Deadband: See model chart.

Compliance: FM, UL. For FM consult factory.

MODEL CHART

Model	Switch* Type SPDT	Ranges	Switch Deadband		Max. Press. psig(bar)
			Low	High	
AP-153-33	Mercury	10 in VAC to 50 in w.c. (2.5 to 12.4 kPa)	5 in w.c. (1.2 kPa)	6 in w.c. (1.49 kPa)	15 (1.03)
AP-153-37	Mercury	1 to 30 psig (.07 to 2.1 bar)	0.4 psig (0.03 bar)	0.75 psig (0.05 bar)	60 (4.14)
AP-153-39	Mercury	10 to 125 psig (.69 to 8.6 bar)	2 psig (0.14 bar)	6 psig (0.04 bar)	160 (11.0)
AP-7021-153-33	Snap	10 in VAC to 50 in w.c. (2.5 to 12.4 kPa)	8 in w.c. (2.0 kPa)	10 in w.c. (2.49 kPa)	15 (1.03)
AP-7021-153-37	Snap	1 to 30 psig (.07 to 2.1 bar)	0.75 psig (0.05 bar)	1.5 psig (0.10 bar)	60 (4.14)
AP-7021-153-39	Snap	10 to 125 psig (.69 to 8.6 bar)	3 psig (0.21 bar)	7 psig (0.48 bar)	160 (11.0)

*Mercury switch units are not CE approved.