

MANUAL



Nagman[®]
PNEUMATIC HAND PUMP
PHP 2

BRIEF PROFILE



An ISO 9001-2015 certified Instrumentation company (since 1972) serving Industries in India & Worldwide thro' the Manufacture & Supply of World-Class Calibration Instruments & Systems like Temperature, Pressure & Signal Calibrators, Black Body Calibration Sources, Pneumatic & Hydraulic Hand Pumps, Dead Weight & Comparison Testers, Calibration Test Benches, etc.

Dear User,

*Thank you for selecting **Nagman's Pneumatic Hand Pump** and becoming a proud owner of this Calibration Instrument.*

We have strived hard to ensure the accuracy of the contents of this manual. We would appreciate any suggestions/feedback to correct any errors noticed and to improve the quality of contents of this Manual

Specifications are subject to change owing to continuous development and we reserve rights to effect Changes / Modifications to this Manual.

Read the Instructions before starting to use the Product.

Wishing you for a long association with us.

For any service related issues, please contact service@nagman.com

VERSION CONTROL

Version No.	Updated on	Updated by
V 1.1	01.09.2022	Nagman

CONTENTS

S.No.	Description	Page No.
1.	Introduction	5
2.	Specification.....	6
3.	Standard Delivery & Optional Accessories	7
4.	Parts Identification	8
5.	Functional Description.....	9
6.	Connection Diagram	10
7.	Safety Instructions	11
8.	Operation – Pressure / Vacuum	13
9.	Troubleshooting / Maintenance.....	14

1. INTRODUCTION

Nagman's calibration hand pump is designed to manually generate pressure between -0.90 to 2 bar of vacuum and pressure for quick and accurate calibration of pressure gauges and other pressure measuring Instruments.

This pump is manufactured with high quality components for calibrating Analog / Digital gauges by comparison method. It can be used for lab and field applications.

There is a pressure / vacuum changeover switch in the pump, which is used for selecting either vacuum or pressure output. It is fitted with a fine Adjustment valve and a Release valve.

It is equipped with a vernier-adjuster, release valve and volume chamber. Volume chamber is used for fine adjustment to desired pressure. The output pressure/vacuum of the hand pump can be adjusted precisely by this vernier adjustment while calibration. Release valve is used to release the pressure/vacuum after calibration.

2. SPECIFICATION

Pressure medium	Air
Working pressure	-0.90 to 2 bar
Vernier-Adjuster	Micro-Adjustable volume control
Minimum Resolution of vernier	1 mbar
Test connection port	1/4" BSP (F)
Gauge / Indicator connection port	3/8" BSP (F)
Stabilization time	1-2 minutes
Dimension	230 × 220 × 70 mm (H×W×D)
Weight	1100 grams (Approx.)

3. STANDARD DELIVERY & OPTIONAL ACCESSORIES

Standard Delivery

- Basic Pump
- Nylon Hose (1 Meter)
- Set of Seals
- Conformance Certificate
- Instruction Manual

Optional Accessories

- Carrying Case (Soft/Hard)
- Analog / Digital Pressure Gauges
- Quick Connector
- Spare Seal Kit
- Set of Adaptors
 - $\frac{1}{8}$ " BSP(F) X $\frac{1}{4}$ " BSP (M) } BSP
 - $\frac{1}{2}$ " BSP(F) X $\frac{1}{4}$ " BSP (M) }
 - $\frac{3}{8}$ " BSP(F) X $\frac{1}{4}$ " BSP (M) }
 - $\frac{1}{8}$ " NPT(F) X $\frac{1}{4}$ " BSP (M) } NPT
 - $\frac{1}{4}$ " NPT(F) X $\frac{1}{4}$ " BSP (M) }
 - $\frac{1}{2}$ " NPT(F) X $\frac{1}{4}$ " BSP (M) }
 - $\frac{3}{8}$ " NPT(F) X $\frac{1}{4}$ " BSP (M) }

4. PARTS IDENTIFICATION

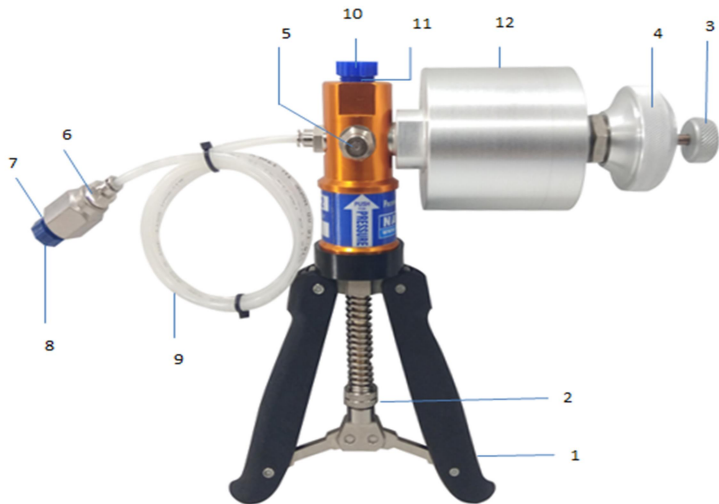

- 1) Pump Handles
- 2) Knurling Thumb Nut
- 3) Pressure Release Valve
- 4) Fine Adjustment Valve
- 5) Pressure / Vacuum selector
- 6) Quick-Fit " Connector - 1/4" BSP (F) (Swivel Adaptor)
- 7) Nylon Washer 1/4"
- 8) Plastic Plug
- 9) Flexible hose to connect unit under test (UUT)
- 10) Pressure Port – 3/8" BSP Female Connection to Connect Master Instrument
- 11) Nylon Washer 3/8"
- 12) Volume Chamber

5. FUNCTIONAL DESCRIPTION

Pressure Release Valve (3):



Used to reduce or release the vacuum / pressure in the system. Minimal force is required to seal the system.

Fine Adjustment Valve (4):



The vacuum / pressure can be finely adjusted by turning this fine adjustment valve either clockwise or anticlockwise to increase or decrease pressure accordingly.

Pressure or Vacuum Selector (5):



Press the selector as indicated in Figure 1 to engage the desired mode. Ensure that the release valve is closed firmly (clockwise motion) prior to pumping.

Knurling Thumb Nut (2) (Over Pressure Protection):







To adjust maximum output pressure of the pump turn the knurling thumb nuts (2) to increase or decrease the stroke length so that the maximum pressure is controlled per stroke.

6. CONNECTION DIAGRAM



1. Master / Reference Measurement
2. Unit Under Test

7. SAFETY INSTRUCTIONS

S. No.	Symbol	Description
1		Read the user manual before operating the instrument.
2		Warning - conditions that may pose hazards to the user.
3		Caution-conditions that may damage the instrument.
4		Special Information

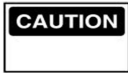

- Check for system fittings and connections tight & leak free.
- Tighten the pressure release valve fully to ensure good sealing.
- 70% of the vacuum / pressure to be generated using handle and remaining 30% can be given using fine adjustment valve.
- Do not attempt to over tight the fittings to the pump as this could lead to damage of sealed joints.
- Release vacuum / pressure before changing through vacuum / pressure selector mode.
- Do not connect pump to External Pressure Source.

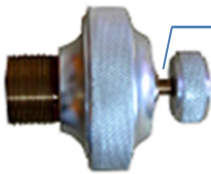

→ Red Mark / Indication

The fine adjustment valve should not be forced to move beyond the red line indicator marked on the body of this pump.



- The connections to the hand held test pump are sealed with 'O' rings, bonded seals & nylon washer to avoid leak.
- Ensure that the adaptors are tightened sufficiently.
- Allow the Pressure to settle for 1-2 Minutes before taking the reading. This is due to thermodynamic effects, setting of seals and expansion of flexible hose.

8. OPERATION – PRESSURE / VACUUM

- Connect the Master / Test Instrument using the appropriate adaptor and seals to the pressure port at the end of the flexible hose (6) or directly to the pressure port on the body (10) using appropriate adaptor.
- Open the fine adjustment valve (4) in anticlockwise direction until Red mark appears.
- Ensure the pressure release valve (3) needle tightened in clock wise direction.
- Pressure / Vacuum calibration can be selected by Pressure / Vacuum selector (5).
- Generate Pressure / Vacuum by squeezing the pump Handles (1) together. Ensure that the handles are fully squeezed together on each stroke to achieve maximum pressure / vacuum output.
- The Output pressure / vacuum can be adjusted using the fine adjustment valve (4) for achieving precise Pressure / Vacuum.
- After calibration is completed, open the Release valve gradually in anticlockwise direction to remove pressure / vacuum before disassembling the measurement system (Master / Test Instrument).
- Remove the master and the test instrument from the pump.

9. TROUBLESHOOTING / MAINTENANCE

If there is no pressure indication in the Master / Test Instrument even after considerable pumping action of the handle, check the following:

- Ensure that the connections between the pump, the hose end and the Test / Master Instrument(s) are tight and then retry pumping.
- Check that the Release Valve is closed.
- Check whether the Pressure / Vacuum selector is left half way in between pressure side & vacuum side. If so, push it firmly in place (either vacuum or pressure side) as needed.

Chances are there that one of the seals in the PHP is leaking and needs to be replaced, if the applied pressure still cannot be obtained.

If functionality of Hand Pump is not normal, please do not Continue Pumping.

Returning Instrument for Service

When returning the instrument to the manufacturer for service, please provide complete information about the problems faced for clear analysis of the problem. The calibrator should be returned in the original packing.

Nagman's liability ceases if :

- Parts are replaced / repaired using spare parts which are not identical to those recommended by the manufacturer.

Nagman's liability is restricted to errors that originated from the factory.

For more details, write to :

**NAGMAN INSTRUMENTS AND ELECTRONICS
PRIVATE LIMITED**

170/1a2, Chennai Bangalore Highway Road,
Sembarambakkam, Chennai - 600 123. INDIA.

Phone: +91-44-66777000, 011, 022, 033

Email: support@nagman.com

Website : www.nagman.com