

## Instruction and Operation Manual

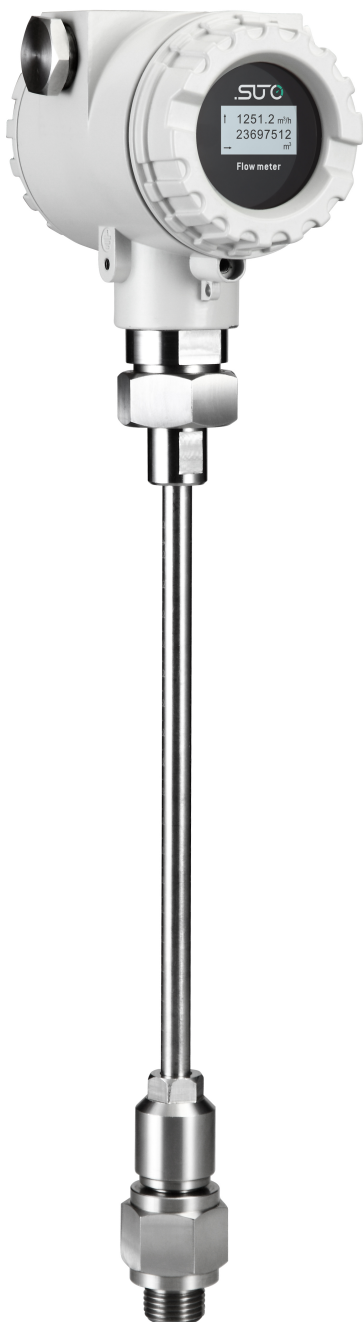

# S450

**Thermal Mass Flow Meter  
for Heavy Duty  
and Ex Applications  
(Insertion)**

Dear Customer,

Thank you for choosing our product.

Please read this manual in full before starting up the device and carefully observe the instructions stated. The manufacturer cannot be held liable for any damage which occurs as a result of non-observance or non-compliance with this manual.

Should the device be tampered with in any manner other than a procedure which is described and specified in the manual, the warranty is void and the manufacturer is exempt from liability.

The device is destined exclusively for the described application.

SUTO offers no guarantee for the suitability for any other purpose. SUTO is also not liable for consequential damage resulting from the delivery, capability or use of this device.

Revision: 2024-1



Last modifications: April, 2024

## Table of Contents

1	Safety instructions.....	4
2	Registered trademarks.....	6
3	Application.....	7
4	Features.....	7
5	Technical data.....	8
5.1	General.....	8
5.2	Electrical data.....	9
5.3	Output signals.....	9
5.4	Accuracy .....	9
5.5	Flow ranges.....	10
6	Dimensional drawing.....	11
7	Determine the installation point.....	12
7.1	Inlet and outlet sections.....	12
8	Installation .....	14
8.1	Installation requirements.....	15
8.2	Installation procedure .....	15
8.2.1	Determine the insertion depth.....	15
8.2.2	Install the Flow Meter.....	16
8.2.3	Removing the Flow Meter .....	18
8.3	Electrical connection.....	18
8.3.1	Connection diagram.....	19
8.3.2	Pin assignment.....	19
9	Signal outputs.....	21
9.1	Analog and pulse outputs .....	21
9.1.1	Analog output.....	21
9.1.2	Pulse output.....	21
9.2	HART output .....	22
9.3	Modbus Interface .....	23
9.4	M-Bus output .....	26
9.5	Connection between S450 Outputs and Customer Equipment....	26
10	Information on the Display.....	29
10.1	Startup.....	29
10.2	Data and Signs.....	30
11	Configuration.....	31
12	Optional accessories.....	34
12.1	Display.....	34
12.2	Service kit.....	34
13	Calibration.....	35
14	Maintenance.....	35
15	Disposal or waste.....	35

## 1 Safety instructions

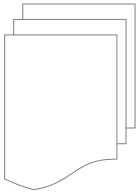

### **Please check if this instruction manual matches the product type.**

Please observe all notes and instructions indicated in this manual. It contains essential information which must be observed before and during installation, operation and maintenance. Therefore this instruction manual must be read carefully by the technician as well as by the responsible user or qualified personnel.

This instruction manual must be available at the operation site of the flow meter at any time. In case of any obscurities or questions, regarding this manual or the product, please contact the manufacturer.



### **WARNING!**

#### **Compressed air!**

**Any contact with quickly escaping air or bursting parts of the compressed air system can lead to serious injuries or even death!**

- Do not exceed the maximum permitted pressure range (see sensors label).
- Only use pressure tight installation material.
- Avoid that persons get hit escaping air or bursting parts of the instrument.
- The system must be pressureless during maintenance work.



### **WARNING!**

#### **Voltage used for supply!**

**Any contact with energized parts of the product, may lead to an electrical shock which can lead to serious injuries or even death!**

- Consider all regulations for electrical installations.
- The system must be disconnected from any power supply during maintenance work.
- Any electrical work on the system is only allowed by authorized qualified personal.

**ATTENTION!****Permitted operating parameters!**

**Observe the permitted operating parameters, any operation exceeding this parameters can lead to malfunctions and may lead to damage on the instrument or the system.**

- Do not exceed the permitted operating parameters.
- Make sure the product is operated in its permitted limitations.
- Do not exceed or undercut the permitted storage and operation temperature and pressure.
- The product should be maintained and calibrated frequently, at least annually.

**General safety instructions**

- It is allowed to use the product in explosive areas. Please contact the manufacturer.
- Please observe the national regulations before/during installation and operation.

**Remarks**

- It is not allowed to disassemble the product.
- Always use spanner to mount the product properly.

**ATTENTION!****Measurement values can be affected by malfunction!**

**The product must be installed properly and frequently maintained, otherwise it may lead to wrong measurement values, which can lead to wrong results.**

- Always observe the direction of the flow when installing the flow meter. The direction is indicated on the housing.
- Do not exceed the maximum operation temperature at the sensors tip.
- Avoid condensation on the sensor element as this will affect the accuracy enormously.

## Storage and transportation

- Make sure that the transportation temperature of the flow meter without display is between -30 ... +70°C and with display between -10 ... +60°C.
- For transportation it is recommended to use the packaging which comes with the flow meter.
- Please make sure that the storage temperature of the flow meter is between -10 ... +50°C.
- Avoid direct UV and solar radiation during storage.
- For the storage the humidity must be <90% with no condensation.

## 2 Registered trademarks

SUTO®	Registered trademark of SUTO iTEC
MODBUS®	Registered trademark of the Modbus Organization, Hopkinton, USA
Android™, Google Play	Registered trademarks of Google LLC

### 3 Application

The S450 Thermal Mass Flow Meter is designed for the explosive areas and is mainly used to measure compressed air and process gases in industrial environments.

The S450 can measure the following parameters for the compressed air or gases:

- Velocity
- Volume flow
- Total consumption

The default factory settings are: Velocity in m/s, Volume flow in m<sup>3</sup>/h and Total Consumption in m<sup>3</sup>. Other units can be programmed by the optional display or the service kit.

### 4 Features

- Direct measurement of mass flow and standard flow without the need of pressure and temperature compensation.
- Insertion type for bigger pipes.
- No moving parts, no clogging.
- All sensor parts which come into contact with the measurement medium are made of stainless steel 316L.
- Robust metal enclosure suitable for outdoor applications in harsh environments.
- Wireless Bluetooth interface for onsite settings.
- Optional display showing flow rate, consumption, medium temperature and diagnostic result.

## 5 Technical data

### 5.1 General

Measuring range	0.4 ... 92.7 sm/s (standard range calibration) 0.8 ... 185 sm/s (max range calibration) 1.0 ... 224 sm/s (high speed calibration) (See Section 4.5 for flow measurement ranges in different tube diameters) * sm/s: standard meter per second
Parameters	Standard unit flow: m <sup>3</sup> /h Available units: m <sup>3</sup> /min, l/min, l/s, cfm, kg/h, kg/min, kg/s Standard velocity unit: m/s
Reference conditions	ISO1217, 20 °C, 1000 mbar (Standard-Unit) DIN1343, 0 °C, 1013.25 mbar (Norm-Unit)
Principle of measurement	Thermal mass flow
Sensor	Resistive sensor
Measured medium	Air, gas (non corrosive gas)
Operating temperature	-40 ... +150°C (Medium temperature) -40 ... +65°C (Ambient temperature)
Humidity of the meas. medium	< 90%, no condensation
Operating pressure	0 ... 1.6 MPa (Applicable for the option A1280) 0 ... 5.0 MPa (Applicable for the option A1279) <b>Note:</b> For pressure above 1.5 MPa you need to use the installation device A530 1106 or A530 1113.
Housing material	Al alloy
Material of the probe tube, sensor head and screwing	Stainless steel 1.4404 (SUS 316L)
Protection class	IP67



Dimensions	See dimensional drawing on the next page
Display (optional)	128 x 64
Tube diameter	From DN15 (1/2") upwards
Screwing thread	G1/2" (ISO 228/1)
Weight	1.75 kg (220 mm version)

## 5.2 Electrical data

Power supply	16 ... 30 VDC, 5 W
--------------	--------------------

## 5.3 Output signals

Analog output	See section <a href="#">9.1.1</a>
Pulse output	See section <a href="#">9.1.2</a>
HART output	See section <a href="#">9.2</a>
Modbus output	See section <a href="#">9.3</a>
M-Bus output	See section <a href="#">9.4</a>

## 5.4 Accuracy

Accuracy*	$\pm(1.5\% \text{ of reading} + 0.3\% \text{ full scale})$
Repeatability	0.25% of reading
Stated accuracy at	Ambient/process temperature $23^{\circ}\text{C} \pm 3^{\circ}\text{C}$ Ambient/process humidity <90% Process pressure at 0.6 MPa

\* The specified accuracy is valid only within the minimum and maximum flow rates that are stated in section [5.5](#).

### 5.5 Flow ranges

The flow ranges are stated under the following conditions:

- Standard flow in air
- Reference pressure: 1000 hPa
- Reference Temperature: +20°C

Inch	DN	S-Range (m <sup>3</sup> /h)	M-Range (m <sup>3</sup> /h)	HS-Range (m <sup>3</sup> /h)
½"	DN15	0.2 ... 45.6	0.4 ... 91.0	0.48 ... 110
¾"	DN20	0.4 ... 89.1	0.9 ... 178	1.09 ... 215
1"	DN25	0.6 ... 148	1.2 ... 295	1.82 ... 357
1½"	DN40	1.5 ... 367	2.9 ... 732	4.36 ... 886
2"	DN50	2.4 ... 600	4.8 ... 1,198	7.26 ... 1,450
2½"	DN65	4.1 ... 1,027	8.2 ... 2,049	12.1 ... 2,480
3"	DN80	5.7 ... 1,424	11.4 ... 2,841	16.9 ... 3,442
4"	DN100	8.7 ... 2,183	17.4 ... 4,357	24.2 ... 5,276
5"	DN125	20 ... 3,420	38 ... 6,824	45.9 ... 8,263
6"	DN150	20 ... 4,930	39 ... 9,839	70.2 ... 11,913
8"	DN200	35 ... 8,786	70 ... 17,533	106 ... 21,229
10"	DN250	55 ... 13,744	110 ... 27,429	166 ... 33,211
12"	DN300	79 ... 19,815	158 ... 39,544	220 ... 47,880

**Remarks:**

- To calculate flow ranges based on pipe and reference conditions in your site, download and install the "Flow range calculator" tool for free from <http://www.suto-itec.com>.
- To fast access the tool download page, enter "flowrange" (without spaces) in the search field, and click the tool in the search result.

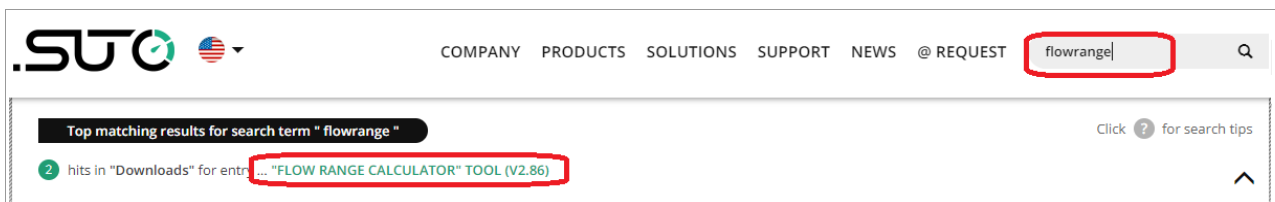

- The total consumption value is saved to the permanent memory every 5 minutes. If within these 5 minutes the device is powered off, it will restore the last consumption value which was saved in the last cycle.

## 6 Dimensional drawing

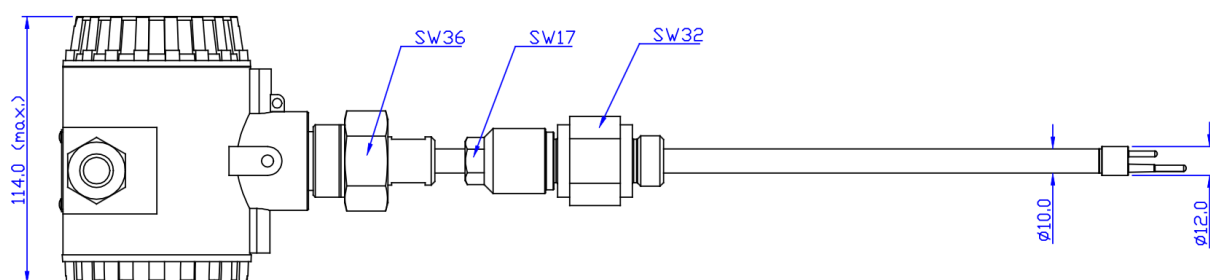
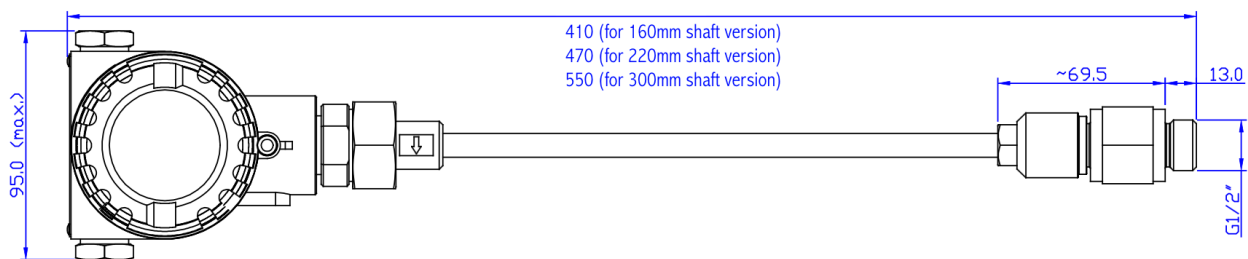

## 7 Determine the installation point

To maintain the accuracy stated in the technical data, the flow meter must be inserted in the centre of a straight pipe section with unhindered flow characteristics.

Unhindered flow characteristics are achieved if the sections in front of the flow meter (inlet) and after the flow meter (outlet) are sufficiently long, absolutely straight and free of obstructions such as edges, seams, curves etc..

Please consider that enough space exists at your site for an adequate installation as described in this manual.



### ATTENTION!

**Wrong measurement may occur if the flow meter is not installed correctly.**

- Pay careful attention to the design of the inlet and outlet sections. Obstructions can cause counter-flow turbulence as well as turbulence in the direction of the flow.
- It is strongly recommend not to install S450 permanently in wet environment which exists usually right after a compressor outlet.

### 7.1 Inlet and outlet sections

The following figures show the necessary equalizing sections in relation to existing obstructions. If it is not possible to observe the indicated equalizing sections, deviations in measuring results have to be expected.

**Remark:** If there is any combination of below situations, the longest straight inlet section must be maintained.

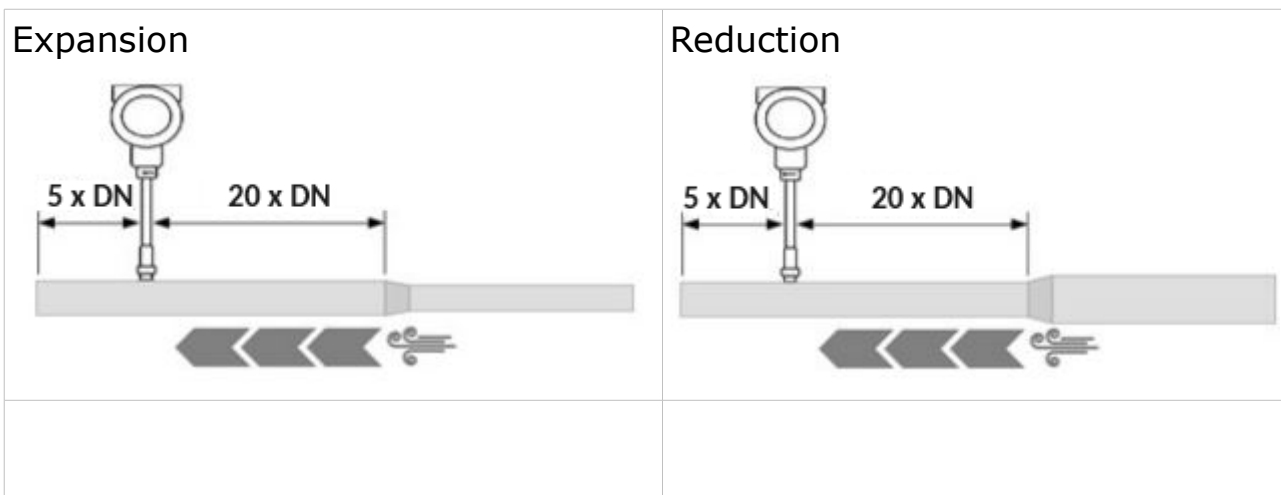

90° Bend

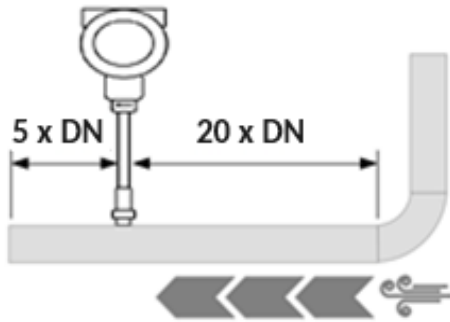

2×90° Bend

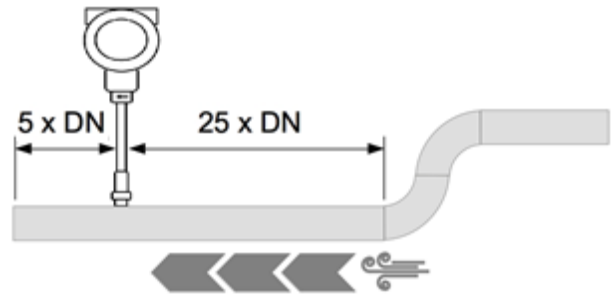

3 dimensional Bend

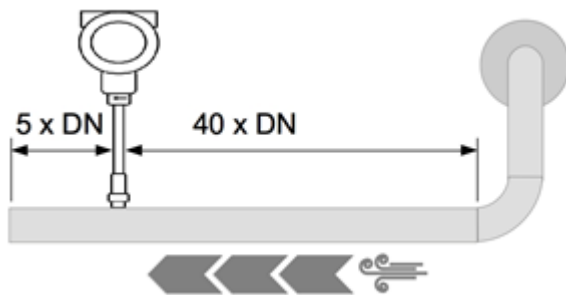

T-piece

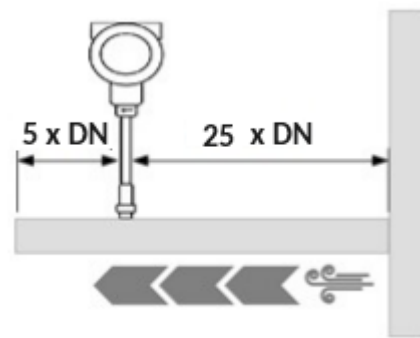

Shut-off valve

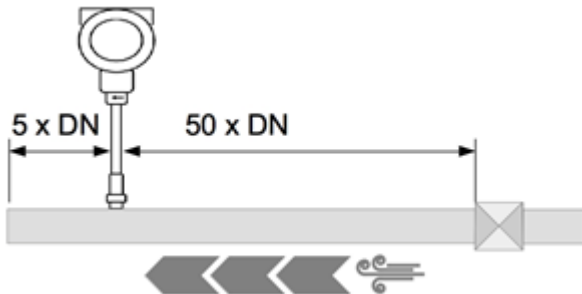

Filter or similar (unknown objects)

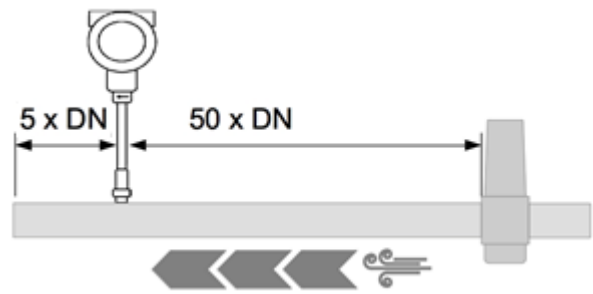

## 8 Installation

Before installing the flow meter, please make sure that all components listed below are included in your package.

<b>Qty</b>	<b>Description</b>	<b>Item No.</b>
1	S450 Thermal Mass Flow Meter	S695 0450
1	Sealing ring	No P/N
1	Alignment key	No P/N
1	G 1/2" ball valve	A554 0008
1	USB Bluetooth dongle	No P/N
1	Instruction manual	No P/N
1	Calibration certificate	No P/N

For pressure above 1.5 MPa you need to use the installation device A530 1106 or A530 1113.

<b>Order No.</b>	<b>Description</b>
A530 1106	High pressure installation device S450, 200 mm. To be used if pressure above 1.5 MPa.
A530 1113	High pressure installation device S450, 400 mm. To be used if pressure above 1.5 MPa.

## 8.1 Installation requirements

To install the flow meter a ball valve or a nozzle is needed.

- The inner thread must be G 1/2".
- The diameter of the hole must be  $\geq 13$ mm. Otherwise the shaft can not be inserted in.

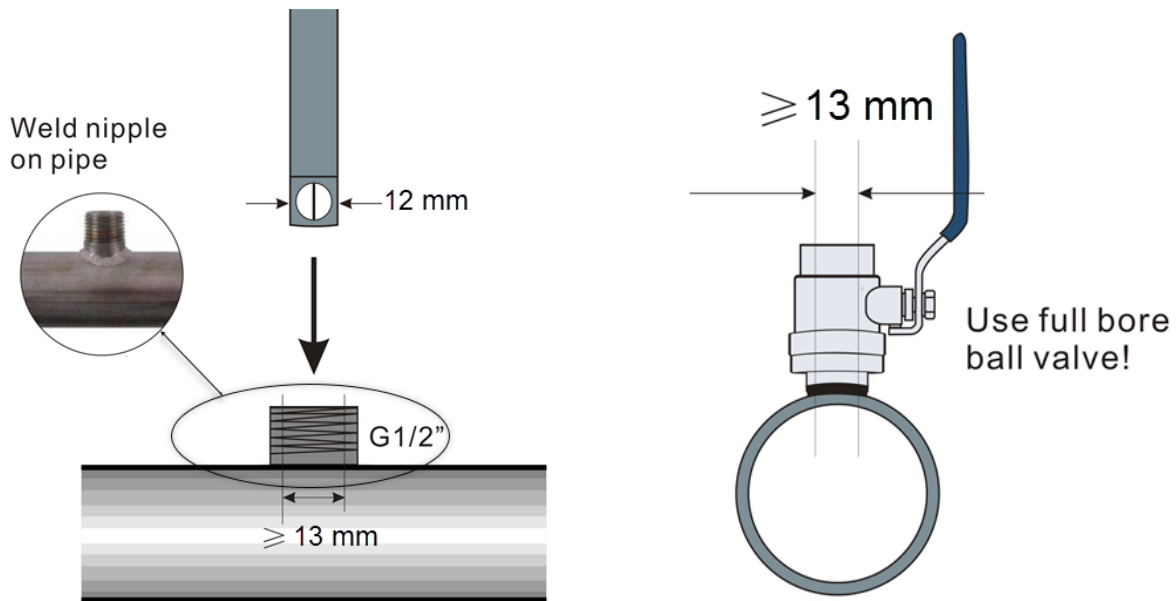

- The flow meter can be installed in any orientation (horizontal, vertical, side and upside-down). Consider the needed straight inlet and outlet sections described in the section 7.1.

## 8.2 Installation procedure

The following steps explain the procedure of an appropriate installation.



### ATTENTION!

**Do not insert the flow meter with strong force. It may happen that the probe tip strikes on the pipe inner wall and causes the flow meter damaged!**

### 8.2.1 Determine the insertion depth

The probe tip must be placed in the center of the pipe. For this the probe shaft has a scale. To determine the right position please calculate the insertion depth as described below.

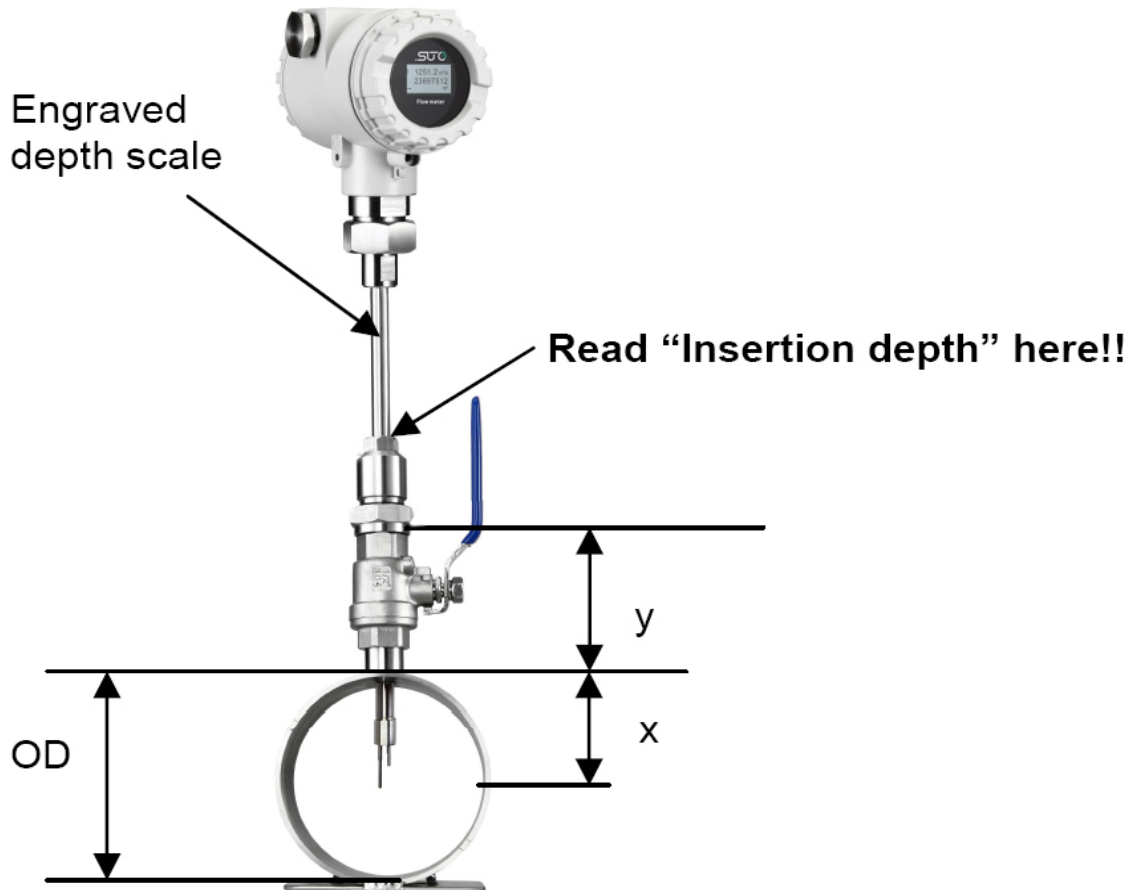

**Insertion depth** =  $x + y$

$x = \frac{OD}{2}$ ;  $OD$  = Outer diameter of pipe

Example for a 2" pipe and an 87 mm ball valve:

$y = 87 \text{ mm}$ ;  $OD = 60.3 \text{ mm}$

$x = \frac{OD}{2} = \frac{60.3 \text{ mm}}{2} = 30.15 \text{ mm}$

**Insertion depth** =  $30.15 \text{ mm} + 87 \text{ mm} = 117.15 \text{ mm}$

### 8.2.2 Install the Flow Meter

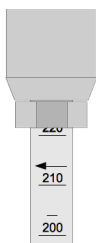

First please observe the flow direction indicated on the shaft. It must match the flow direction of the compressed air or gas.

1. Close the ball valve.

2. The probe tip must be completely covered by the connection head (see photo on the left).





3. Underlay the "O-shaped" sealing ring to the groove in the connection head.

4. Screw the connection head tightly to the ball valve

5. Align the flow meter with the flow direction by observing the flow direction indicated on the shaft.

6. Open the ball valve and tighten the clamp sleeve manually.

7. Move the flow meter slightly to the determined insertion depth by means of the scale.

8. Tighten the clamp sleeve at the connection head so that the flow meter can no longer be moved by the pressure in the pipe. However it should be possible to move the flow meter shaft by hand.

9. With the aid of the alignment key, make sure that the actual flow direction is same as the arrow shown on the housing. (The angle deviation should not be larger than  $\pm 2^\circ$  to the perfect position, please see picture on the next page.).

10. Tighten the clamp sleeve with the clamping torque 20 ... 30 Nm.

11. Check the installation depth again because sometimes the shaft is moved from its original position by the compressed air.

Maximum angle deviation of a proper installation:

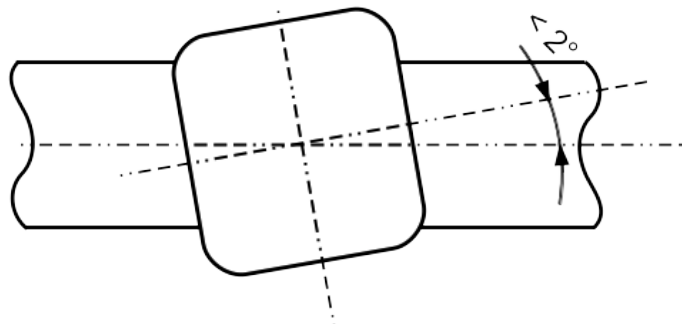

### 8.2.3 Remove the Flow Meter

1. Hold the flow meter firmly.
2. Release the clamp sleeve from the connection head.
3. Pull out the shaft slowly until the value "10" can be read at the scale.
4. Close the ball valve.
5. Release the connection head and unscrew the flow meter.

### 8.3 Electrical connection

When installing the cables please consider following point:

- Keep the stripped and twisted length of cable shield as short as possible.
- Screen and ground the signal lines.
- Unused cable entries must be closed with closers.
- Cable outer diameter should be between 6 and 8 mm.
- Single wire cross-section should be between 0.25 ... 0.75 mm<sup>2</sup>.
- The thread size for the cable glands is M20 / 1.5.

### 8.3.1 Connection diagram

Remove the back cover from the S450, and the pin layout is shown below.

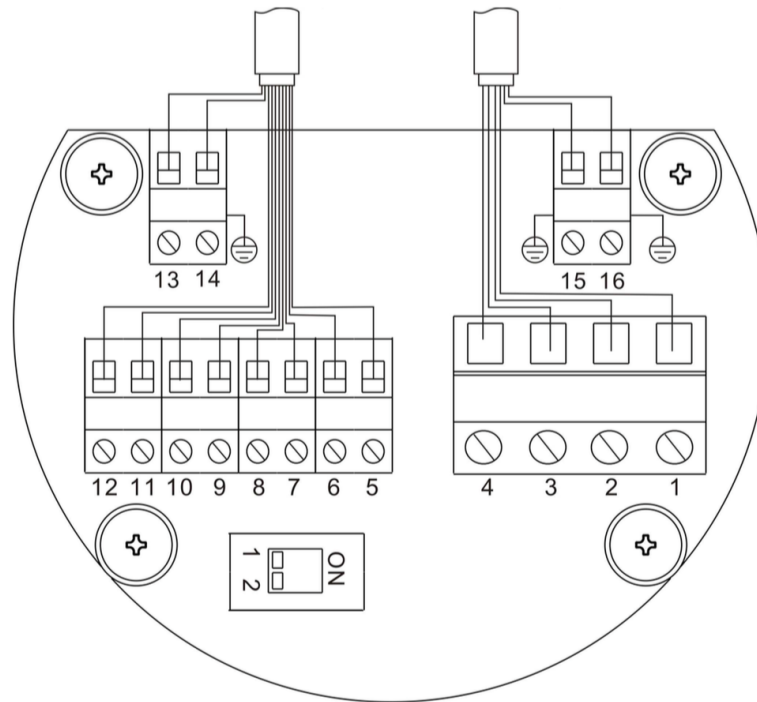

### 8.3.2 Pin assignment

The S450 provides four output options. The pin assignment of these options are given in the following table.

Pin	Output options			
	Pulse and analog	Modbus	M-Bus	HART
1	$GND_{SDI}$	$GND_{SDI}$	$GND_{SDI}$	$GND_{SDI}$
2	$+V_B$	$+V_B$	$+V_B$	$+V_B$
3	$-V_B$	$-V_B$	$-V_B$	$-V_B$
4	SDI	SDI	SDI	SDI
5	DIR	DIR	DIR	DIR
6	DIR	DIR	DIR	DIR
7	SW	SW	SW	NA
8	SW	SW	SW	NA
9	$-I_1$	$-I_1$	$-I_1$	$-I_1 / HART$

10	$+I_1$	$+I_1$	$+I_1$	$+I_1$ / HART
11	$-I_2$	+D	M	NA
12	$+I_2$	-D	M	NA
13	NA	$GND_M$	NA	NA
14	Earth	Earth	Earth	Earth
15	Earth	Earth	Earth	Earth
16	Earth	Earth	Earth	Earth

### Legend to pin assignment

SDI	Digital signal (internal use)	SW	Isolated Pulse output
$GND_{SDI}$	Ground for SDI	DIR	Flow direction input
$+V_B$	Positive supply voltage	D+	Modbus data+
$-V_B$	Negative supply voltage	D-	Modbus data -
$+I_1$	Positive signal output (analog output 1)	M	M-Bus data
$-I_1$	Negative signal output (analog output 1)	NA	Not applicable
$+I_2$	Positive signal output (analog output 2)		
$-I_2$	Negative signal output (analog output 2)		

## 9 Signal outputs

### 9.1 Analog and pulse outputs

If the S450 is purchased with the output option of analog and pulse signals, it provides 2 analog outputs and 1 pulse output. All signals are electrically isolated.

#### 9.1.1 Analog output

The analog output can be used as an active output (current is sourced through the positive connection pin) or passive output. In the passive configuration, a current signal is modulated into the external signal voltage.

- Active : 4 to 20mA,  $R_L < 400 \Omega$
- Passive : 4 to 20mA, supply voltage 18 ... 30 VDC,  $R_L < 500 \Omega$
- For HART :  $R_L \geq 250 \Omega$
- Uncertainty :  $< 0.3 \%$  of reading
- Resolution : 0.005 mA

#### 9.1.2 Pulse output

No switch and polarity are required. Galvanic isolation.

Max. rating: 30 VDC, 200 mA

Pulse width: 10 ... 100 msec (depending on the flow rate)

The maximum number of pulse per second is limited to 45. As a result, depending on the flow rate and the selected consumption unit, the maximum flow rates are listed in the following table.

Pulse / consumption unit	Max flow		
	1/1	1/10	1/100
m <sup>3</sup> /h	162,000	1,620,000	16,200,000
m <sup>3</sup> /min	2,700	27,000	270,000
l/min	2,700	27,000	270,000
cfm	2,700	27,000	270,000
Kg/h	162,000	1,620,000	16,200,000
Kg/min	2,700	27,000	270,000
Kg/s	45	450	4,500
	Default	Configurable by service software	

## 9.2 HART output

If the S450 is purchased with the output option of HART, the HART signal is modulated on analog output 1. In case S450 is used in a multi-drop configuration (more than 1 slave on the 4-20 mA line) the analogue output can not be used anymore.

<b>Device type</b>	<b>: Slave</b>
Polling address	: 1 to 15 Bus address can be set through software
Physical interface	: BELL 202
Protocol version	: V 5.2
Tag	: S450
Tag description	: Flow meter
Frame/parity/Stop	: 8, 0, 1

### 9.3 Modbus Interface

If the S450 is purchased with the output option of Modbus, it provides one analog output and one pulse output.

The Modbus communication requires to activate terminal resistors at the last device on the bus system. If the S450 is the last device on the bus system, the DIP switches on the connector board should be set to "ON" position.

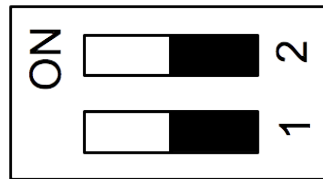

Termination resistor network switch

Device type	Slave
Address range	1 to 251 Bus address can be set through software
Physical interface	RS485 in accordance with EIA/TIA-485 standard
Baud rates	1200, 2400, 4800, 9600, 19200, 38400, 57600, 115200 Baud
Transm. mode	ASCII, RTU
Response time	Direct data access = 0 to 255 ms (configurable)

The default Modbus communication settings are shown as below.

Mode	RTU
Baud rate	19200
Device address	Last two digits of serial number
Framing / parity / stop bit	8, N, 1
Response time	1 second
Response delay	0 ms
Inter-frame spacing	7 char

### Response message that the device returns to the master:

- Function code: 03

The information for the byte order is shown in the table below:

Byte Order	Sequence				Data Type
	1st	2nd	3rd	4th	
1-0-3-2	Byte 1 (MMMMMMMM*)	Byte 0 (MMMMMMMM *)	Byte 3 (SEEEEEEE)	Byte 2 (EMMMMMMM *)	FLOAT
1-0-3-2	Byte 1	Byte 0 LSB	Byte 3 MSB	Byte 2	UINT32 INT32
1-0	Byte 1 MSB	Byte 0 LSB	---	---	UINT16 INT16
1-0	Byte 1 XXX *	Byte 0 DATA	---	---	UINT8 INT8

\* S: Sign, E: Exponent, M: Mantissa, XXX: no value

### Explanations of MSB and LSB

**MSB** MSB refers to Most Significant Byte first, which follows the Big-Endian byte order.

For example, if the main system follows the MSB first order:  
When the 4-byte floating number, in the order of Byte1-Byte0-Byte3-Byte2, is received from the slave (sensor), the master must change the byte order to Byte3-Byte2-Byte1-Byte0 for the correct display of the value.

**LSB** LSB refers to Least Significant Byte first, which follows the Little-Endian byte order.

For example, if the main system follows the LSB first order:  
When the 4-byte floating number, in the order of Byte1-Byte0-Byte3-Byte2, is received from the slave (sensor), the master must change the byte order to Byte0-Byte1-Byte2-Byte3 for the correct display of the value.

**Remarks:** Modbus communication settings as well as other settings can be changed by the service App or through the windows based **Service Software**.



**Available measurement channels:**

<b>Channel description</b>	<b>Unit</b>	<b>Resolution</b>	<b>Format</b>	<b>Length</b>	<b>Modbus Register address</b>
Velocity	m/s	0.1	FLOAT	4-Byte	0
Flow	m <sup>3</sup> /h	0.1	FLOAT	4-Byte	6
Consumption	m <sup>3</sup>	1	UNIT32	4-Byte	12
Reverse consumption	m <sup>3</sup>	1	UNIT32	4-Byte	18
Medium temperature	°C	0.1	FLOAT	4-Byte	24
Ambient temperature	°C	0.1	FLOAT	4-Byte	36

### 9.4 M-Bus output

If the S450 is purchased with the output option of M-Bus, it provides one analog output and one pulse output besides the M-Bus output.

- Device type** : **Slave**
- Address range** : 1 to 251  
Bus address can be set through software
- Physical interface** : Meter-Bus, EN1434-3
- Baud rates** : 300, 2400, 9600 Baud
- Frame/parity/Stop** : 8, E, 1

### 9.5 Connection between S450 Outputs and Customer Equipment

This section provides figures to show how outputs supported by the S450 connect with the customer equipment.

In the following figures, the **SUTO Instrument** indicates the S450.

Analog output (Isolated)

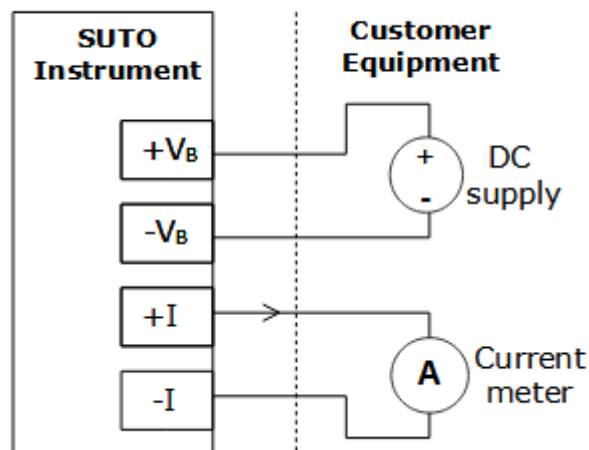

Pulse output (passive)

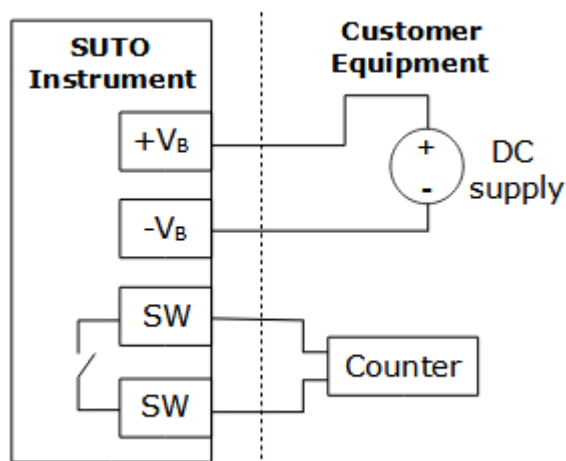

Modbus/RTU output

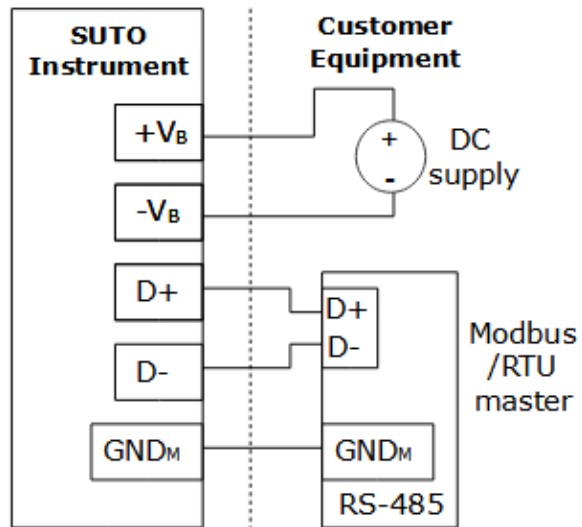

M-Bus output

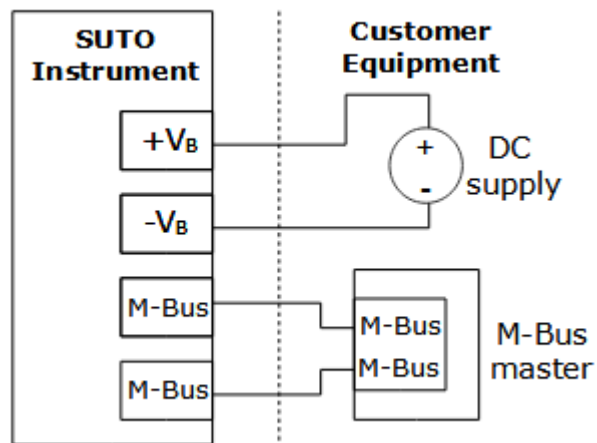

HART output

Active HART output

**Note:** The active HART output can only support one HART slave.

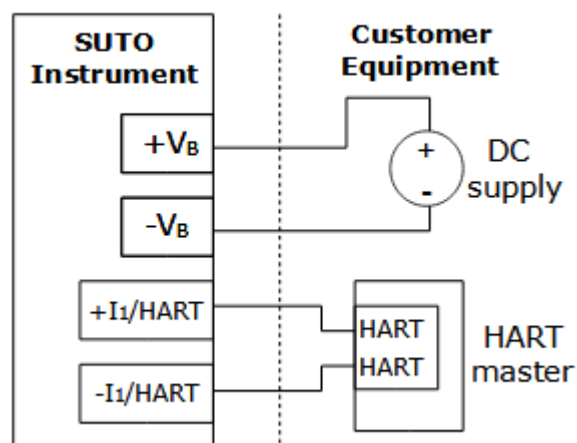

Passive HART output

**Note:** If you want to connect multiple slaves on the bus (multidrop), use the passive solution.

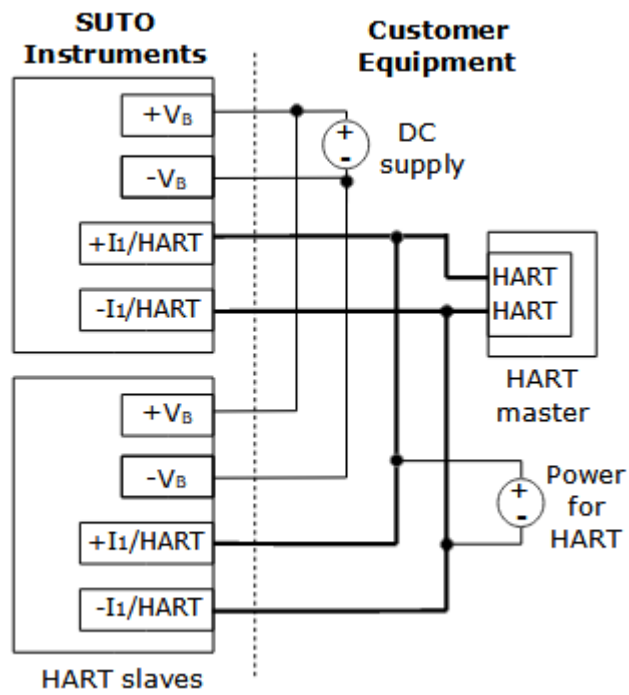

## 10 Information on the Display

When the S450 comes with a display, startup information, measuring values, and more can be viewed on the display.

### 10.1 Startup

Initializing ...

2 sec.

Software: 1.31  
Hardware: 1.20

Software and hardware versions

2 sec.

1345.6 m<sup>3</sup>/h  
1345670 m<sup>3</sup>

Online measuring values: flow and consumption. After resetting, the S450 has a warm-up time of about 20 seconds. During the period, the flow is zero.

M: 43.6 °C  
A: 26.7 °C  
E: 00 00 00 00

Medium, ambient temperature, and error code, which are shown every 5 seconds.

## 10.2 Data and Signs

This section explains data and signs on the display when the S450 goes into a normal working state.

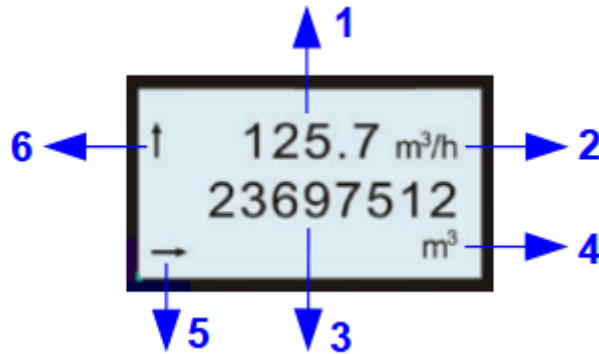

- |   |  |
|---|--|
| 1 | Flow value, 6 digits   |
| 2 | Flow unit  |
| 3 | Consumption value, 10 digit  |
| 4 | Consumption unit   |
| 5 | Flow direction sign. <ul style="list-style-type: none"> <li>←: default flow direction</li> <li>→: reverse flow direction</li> </ul>  |
| 6 | Alarm sign. <ul style="list-style-type: none"> <li>No sign: indicates no alarm.</li> <li>↑: indicates an alarm was raised.</li> <li>↓: indicates the overflow alarm was raised.</li> </ul> |

## 11 Configuration

S450 enables you to configure parameter settings according to on-site requirements. The table below gives an overview about the available settings.

Parameters	Available settings	Default
Measurement	Tube diameter	54.0
	Flow unit	m <sup>3</sup> /h
	Consumption unit	m <sup>3</sup>
	Reference conditions	P <sub>s</sub> = 1000 hPa, T <sub>s</sub> = 20°C
	Gas type selection	Air
	Consumption counter	0 m <sup>3</sup>
	Operation pressure	0.6 MPa
	Flow direction	Standard
Analog output 1	Measurement channel	Flow
	Scaling	4 mA: 0 m <sup>3</sup> /h 20 mA: max flow
	Active / passive	Active
Analog output 2	Measurement channel	Medium Temperature
	Scaling	4 mA: -50°C 20 mA: 150°C
	Active / passive	Active
Pulse output	Pulse / Alarm	Pulse
	Pulses per consumption unit	1
HART	Fieldbus address	0
	Manufacturer ID	255
	Device type code	0
Modbus	Device address	1
	Baudrate	19200
	Framing/parity/Stop bit	8, N, 1
	Transmission mode	RTU
M-Bus	Address	0
	Manufacturer code	END
	Baudrate	300

To configure the S450 settings, use the service software, which can be downloaded on the SUTO website.

1. Install the S450 service software on your Windows® PC as steps below:
  - a. Access [www.suto-itec.com/en/downloads/#](http://www.suto-itec.com/en/downloads/#), and input "S450" as key word to get the service software, as below:

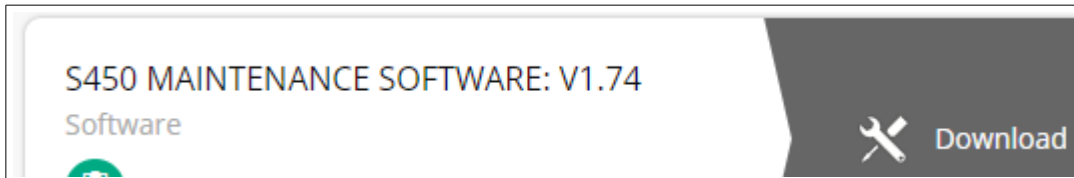

- b. Download the software and unzip it on your PC.
  - c. Run *Service Software S450 V1.74.exe* to install the software.
2. Power up the S450.
3. If the PC does not provide the Bluetooth interface, insert the USB Bluetooth dongle provided in the delivery package to the PC.
4. Pair the Bluetooth of the PC and the S450. For details, see *S450/S452 USB stick and Bluetooth Dongle IM*.
5. On the PC, run the service software and follow the onscreen instructions to complete the configuration. You can also refer to the online help file for more information.

**Remark:**

To enable a stable Bluetooth communication, ensure the following:

- Distance between the S450 and the PC must be not more than 5 meters.
- The PC Bluetooth antenna must point roughly at the direction of the display (front part).



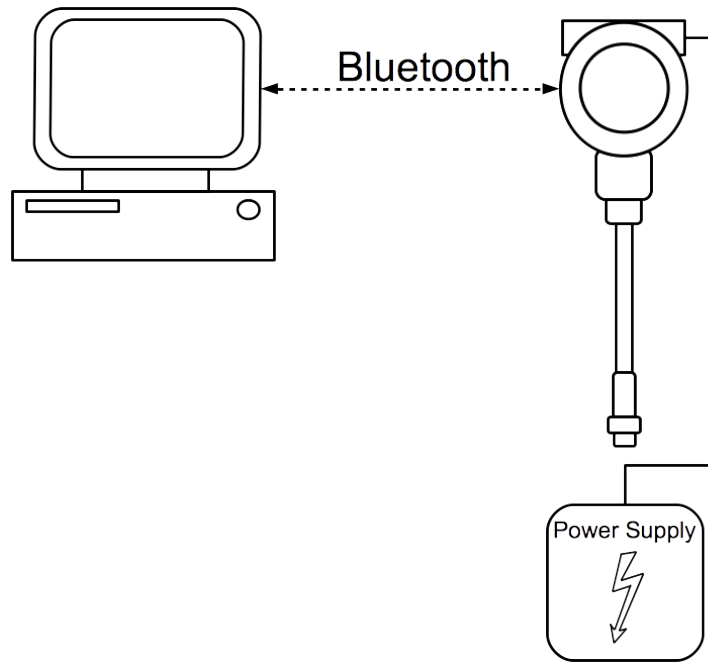

## 12 Optional accessories

### 12.1 Display

With the Sensor display it is possible to show the values of velocity, flow rate, consumption and error messages.

### 12.2 Service kit

The service kit is designed to enable the wired communication between the PC and an S450.

The diagram below shows the cable connection between an S450 and a PC through the service kit. Please ensure that S450 or the service kit is connected with the power supply because the USB port cannot provide enough power to both of them.

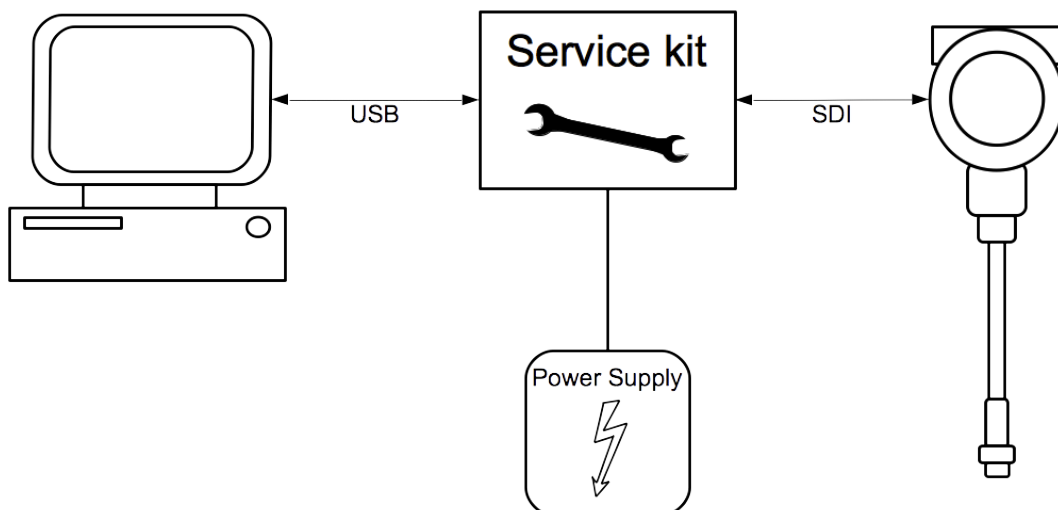

## 13 Calibration

The flow meter is calibrated ex work. The exact calibration date is printed on the certificate which is supplied together with the instrument. The accuracy of the instrument is regulated by the on site conditions, parameters like oil, high humidity or other impurities can affect the calibration and furthermore the accuracy. However it is recommended to calibrate the instrument at least once per year. The calibration is excluded from the instruments warranty. For this please contact the manufacturer.

## 14 Maintenance

To clean the instrument it is recommended to use distilled water or isopropyl alcohol only. If the contamination can not be removed the instrument must be inspected and maintained by the manufacturer.

## 15 Disposal or waste



Electronic devices are recyclable material and do not belong in the household waste.

The device, the accessories and its packings must be disposed according to your local statutory requirements.

The dispose can also be carried by the manufacturer of the product. Please contact the manufacturer for details.

---

**SUTO iTEC GmbH**

Grißheimer Weg 21  
D-79423 Heitersheim  
Germany

Tel: +49 (0) 7634 50488 00  
Email: [sales@suto-itec.com](mailto:sales@suto-itec.com)  
Website: [www.suto-itec.com](http://www.suto-itec.com)

**SUTO iTEC (ASIA) Co., Ltd.**

Room 10, 6/F, Block B, Cambridge Plaza  
188 San Wan Road, Sheung Shui, N.T.  
Hong Kong

Tel: +852 2328 9782  
Email: [sales.asia@suto-itec.com](mailto:sales.asia@suto-itec.com)  
Website: [www.suto-itec.com](http://www.suto-itec.com)

---

**SUTO iTEC Inc.**

5460 33rd St SE  
Grand Rapids, MI 49512  
USA

Tel: +1 (616) 800-7886  
Email: [sales.us@suto-itec.com](mailto:sales.us@suto-itec.com)  
Website: [www.suto-itec.com](http://www.suto-itec.com)

---

All rights reserved ©

Modifications and errors reserved

S450\_im\_en\_V2024-1