

Dust Generator

SAG 440



SAG 440 ASHRAE Dust Disperse

The SAG 440 ASHRAE dust disperser has been especially developed to meet the requirements as defined by the ASHRAE 52.2 and DIN EN 779 standards for testing the performance of particulate air filters. Due to the particular physical properties of ASHRAE test dust it was necessary to adapt the instrument to this material. The SAG 440 is particularly suited for dosing dusts containing a certain proportion of fibres and provides excellent results when producing test dust to check separation efficiencies.

Principle

To generate a test aerosol a defined amount of test dust is put on the feeding belt, the dosing wheel adds a set quantity to the dust uptake nozzle from where it is forwarded pneumatically to the test duct. To avoid electrostatic effects it is possible to neutralise the particles with a neutraliser, e.g. Topas EAN 581.

Special Advantages

- High concentration range
- Constant and reproducible dosing rate over a wide concentration range makes it suitable for several applications
- Continuous operation
- Refillable during operation – ideal for long term tests
- Optional remote control unit for manual or computer control

Applications

- Aerosol preparation for the determination of the filter dust holding capacity according to EN 779, ASHRAE 52.2
- Ideal for testing the separation efficiencies of filters
- Evaluation and calibration of dust samplers and monitors

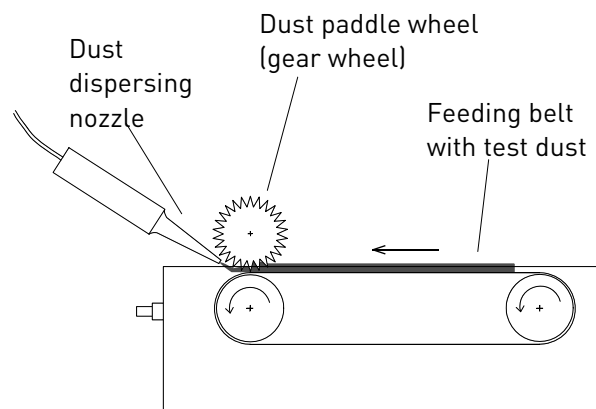

Schematic of the SAG 440

Specifications

Details

The dust paddle wheel and the dust dispersing nozzle are laid out in accordance with the EN 779 and ASHRAE standards. The concentration of the test aerosol can be varied by adjusting the speed of the belt and dust paddle wheel.

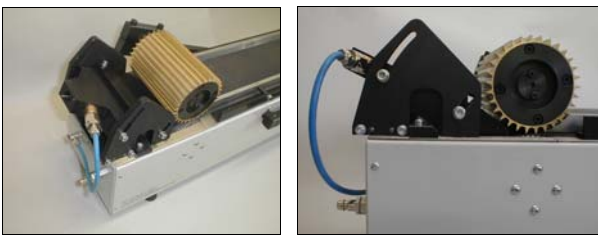

Side View of the dust paddle wheel and dust dispersing nozzle

The compressed air supply must provide clean, dry and oil-free air.

Electrostatic Aerosol-Neutralizer

A common problem to dry dispersion aerosols is the build-up of electrical charges on particles as they touch the surface in the generator.

This problem can be resolved by passing the aerosol through a chamber containing a bipolar ion source (corona discharger). The Topas EAN 581 neutraliser applies this principle and can be ordered separately.

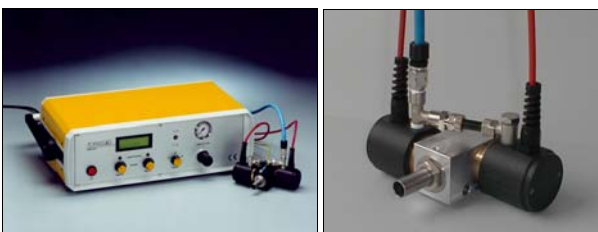

Electrostatic Aerosol Neutralizer EAN 581 (le); Mixing chamber with ionization heads (ri)

Technical Data

Type of dust	ASHRAE 52.2 test dust 72% SAE fine 23% powdered carbon 5% cotton linters Other fibre-containing dusts (e.g. DMT-dust type 8)
Dosing range	4...350 g/h
Dosing channel (W x H)	114.5 x 20 mm
Compressed air supply	7 m ³ /h (5 bar), max. 6 bar
Power supply	100...240 V AC, 50-60 Hz
Size of the uptake nozzle	1150 x 290 x 400 mm
Size of the Control Unit	300 x 130 x 185 mm
Weight	33.5 kg

QMS certified to
DIN EN ISO 9001.



12 100 11908 TMS

For more information please
visit our website at
www.topas-gmbh.de

Specifications are subject to
change without notice.

© Copyright 2019 Topas GmbH.

