

# User's Guide

Shop online at



[www.omega.com](http://www.omega.com)

e-mail: [info@omega.com](mailto:info@omega.com)

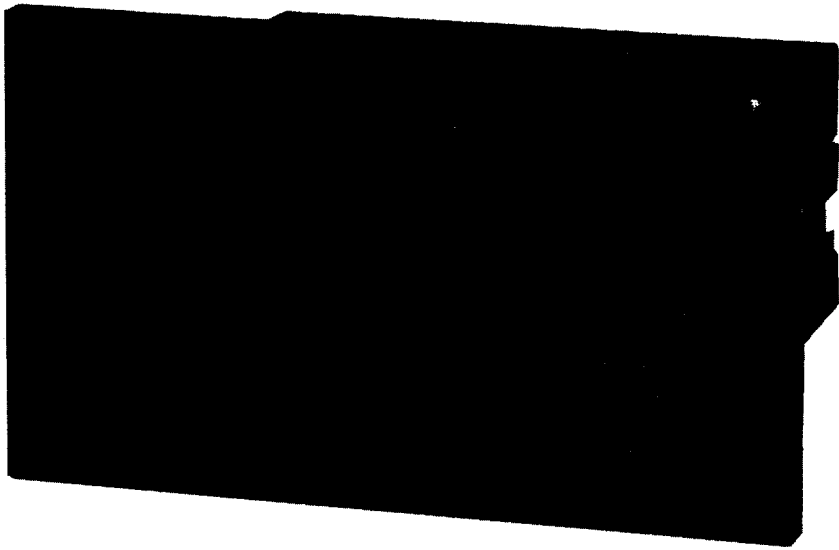

# DPF10 SERIES Mini-Batcher



OMEGAnet® Online Service  
www.omega.com

Internet e-mail  
info@omega.com

### Servicing North America:

**USA:**  
ISO 9001 Certified

One Omega Drive, P.O. Box 4047  
Stamford CT 06907-0047  
TEL: (203) 359-1660  
e-mail: info@omega.com

FAX: (203) 359-7700

**Canada:**

976 Bergar  
Laval (Quebec) H7L 5A1  
TEL: (514) 856-6928  
e-mail: info@omega.ca

FAX: (514) 856-6886

### For immediate technical or application assistance:

**USA and Canada:** Sales Service: 1-800-826-6342 / 1-800-TC-OMEGA®  
Customer Service: 1-800-622-2378 / 1-800-622-BEST®  
Engineering Service: 1-800-872-9436 / 1-800-USA-WHEN®  
TELEX: 996404 EASYLINK: 62968934 CABLE: OMEGA

**Mexico:**

En Español: (001) 203-359-7803  
FAX: (001) 203-359-7807

e-mail: espanol@omega.com  
info@omega.com.mx

### Servicing Europe:

**Benelux:**

Postbus 8034, 1180 LA Amstelveen, The Netherlands  
TEL: +31 (0)20 3472121  
Toll Free in Benelux: 0800 0993344  
e-mail: sales@omegaeng.nl

FAX: +31 (0)20 6434643

**Czech Republic:**

Rudé armády 1868, 733 01 Karviná 8  
TEL: +420 (0)69 6311899  
Toll Free: 0800-1-66342

FAX: +420 (0)69 6311114  
e-mail: czech@omega.com

**France:**

9, rue Denis Papin, 78190 Trappes  
TEL: +33 (0)130 621 400  
Toll Free in France: 0800-4-06342  
e-mail: sales@omega.fr

FAX: +33 (0)130 699 120

**Germany/Austria:**

Daimlerstrasse 26, D-75392 Deckenpfronn, Germany  
TEL: +49 (0)7056 9398-0  
Toll Free in Germany: 0800 639 7678  
e-mail: info@omega.dl

FAX: +49 (0)7056 9398-29

**United Kingdom:**  
ISO 9002 Certified

One Omega Drive, River Bend Technology Centre  
Northbank, Irlam, Manchester  
M44 5BD United Kingdom  
TEL: +44 (0)161 777 6611  
Toll Free in United Kingdom: 0800-488-488  
e-mail: sales@omega.co.uk

FAX: +44 (0)161 777 6622

---

It is the policy of OMEGA to comply with all worldwide safety and EMC/EMI regulations that apply. OMEGA is constantly pursuing certification of its products to the European New Approach Directives. OMEGA will add the CE mark to every appropriate device upon certification.

The information contained in this document is believed to be correct, but OMEGA Engineering, Inc. accepts no liability for any errors it contains, and reserves the right to alter specifications without notice.

**WARNING:** These products are not designed for use in, and should not be used for, patient-connected applications.

## TABLE OF CONTENTS

SPECIFICATIONS .....	1
MOUNTING .....	3
WIRING .....	4
THEORY OF OPERATION .....	6
INPUT & OUTPUT JUMPER SELECTIONS .....	7
FRONT PANEL OPERATIONS .....	8
PROGRAMMING FLOW CHART .....	8
DEFINITIONS OF MENU PROMPTS .....	9
CALCULATING SCALE FACTORS .....	11
PROGRAMMING .....	12
RS232 & RS422 INTERFACE CARD OPERATION .....	17
RS232 & RS422 WIRING .....	19
ANALOG OUTPUT OPTION .....	20
TROUBLESHOOTING GUIDE .....	21
WARRANTY	

# SPECIFICATIONS

## Features

- 5 Digit Scaling Factor
- Display Rate, Batch Size and (Batch Total or Grand Total)
- Second B Relay Programmable for Output at Prewarn or selected Batch/Grand Total
- Pulse Input - 10 kHz Max.
- Security Lockout
- RS422/RS232 Serial Communication
- NEMA 4X / IP65 Front Panel
- 30mV Magnetic Pickup Inputs
- 4-20mA or 0-20mA Analog Output

## Application:

This miniature batcher is ideal for all batching applications. The display will show Batch Amount, Rate and Batch/Grand Total at the push of a button. The Start and Stop buttons make batching simple.

## Description:

The DPF10 is a 6 digit totalizer and 4.5 digit ratemeter with two relay outputs. One output is dedicated to the batch amount (Preset A), the other can be activated for Prewarn or Batch/Grand Total. The unit can count up to the preset (reset to 0) or down from the preset (set to preset). Start, Stop and Reset functions can be activated from the front panel or remote inputs.

An analog output (assignable for Rate or Batch Amount) is available for data logging.

Up to 99 units can communicate to a host computer on a single RS232 or RS422 loop.

## Specifications:

**Display:** 6 digit, 0.55" High LED

### Input Power:

110 VAC  $\pm$  15% or 12 to 15 VDC

220 VAC  $\pm$  15% or 12 to 15 VDC

24 VAC  $\pm$  15% or 12 to 15 VDC

**Current:** 250 mA DC max. or 6.5 VA AC

**Output Power:** (AC powered units only)  
+12 VDC @ 50 mA, unregulated -10 + 50%

### Temperature:

Operating:

+32°F (0°C) to +130°F (+54°C)

Storage:

-40°F (-40°C) to +200°F (93°C)

**Humidity:** 0-90% Noncondensing

**Memory:** EEPROM stores data for 10 years if power is lost.

## Inputs:

3: High Impedance DC pulse input 4-30 VDC (high), Open or 0-1 VDC (low), 10 k $\Omega$  imp. 10 kHz max. speed.

3M: Mag. Input, accepts 30mV input (50 V max.) signals 10 K $\Omega$  imp. 5 kHz max.

## Stop / Reset:

Front Panel:

STOP/RST button stops batch if batch is running, Resets displayed value and control output if batch is stopped.

Remote:

4-30 VDC, positive edge: stops batch if batch is running, Resets batch amount if batch is stopped.

**NOTE:** Hold either front or remote reset active to inhibit any start inputs.

## Start:

Front Panel:

START button Starts batch by energizing Relay A (and Relay B if Prewarn selected).

Remote:

4-30 VDC, positive edge: Starts batch by energizing Relay A (and Relay B if Prewarn selected).

**Scaling Factor (K-Factor):** A user programmable K-Factor is used to convert the input pulses to engineering units. The 5 digit K-Factor divider, with decimal keyed into any position, allows easy direct entry of any K-Factor from 0.0001 to 99999.

**Presets:** Two control outputs are provided. A 5 digit value can be entered for both presets. The decimal point location is the same as the counter (No decimal in Batch Total counter).

### PRESET A:

The preset A output is dedicated to the batch amount. When START is activated, Relay A will energize and remain on until the batch is complete or the batch is stopped.

### PRESET B:

The preset B output can be programmed to activate as a Prewarn (for two stage batch control) or activate on Batch Total or Grand Total (selectable).

When set for PREWARN, Relay B will energize when START is activated and drop out at Prewarn number before preset.

When set for Batch Total or Grand Total, Relay B will activate when the batch total or grand total counts up to preset B amount. The output ON time can be set for a duration (0.01 to 99.99 sec.) or latched (0.00 setting). If a value other than 0.00 is set for the duration, the batch total or grand total will auto-reset at preset B.

## Control Outputs:

Relays:

2 each N.O. Relay; 5 Amps 120/240 VAC or 28 VDC. (N.C. relay contacts and NPN transistor output available with solder jumpers.

Transistor output is internally pulled up to 10 VDC through relay coil, sinks from 10 VDC to 0.5 V @ 100 mA)

Analog Output:

An optional 4-20mA (0-20mA) output is available for the Mini-Batch series. The output can be programmed to track rate or batch amount. Connections are via a 2 terminal pluggable screw connector. Programming is accomplished by using the front panel in conjunction with rear dip switches. Accuracy:  $\pm$  25% FS worst case. Compliance Voltage: 3 to 30 VDC non inductive.

# SPECIFICATIONS

(continued)

**Lockout:** Unauthorized front panel changes can be prevented by entering a user selected 5 digit code. The front panel can be completely locked out (except Start & Stop) or the preset can remain accessible.

**Ratemeter:** Accurate to 4 1/2 digits ( $\pm 1$  display digit). The rate display updates once per second. The rate meter can be programmed to sample from 2 to 24 seconds maximum, and auto-range up to 5 digits of significant information. The ratemeter displays in units per second, minute or hour.

**Batch or Grand Totalizer:** In addition to viewing the batch amount, a second counter can be viewed. This counter is programmable to count either the number of batches (Batch Total) or the grand total count (Grand Total).

**RS232/RS422 Serial Interface:** If the serial interface option is supplied, up to 99 units can be linked together. (The terminal addressing the unit must be capable of driving all loads in the loop.) Unit status and new set points can be communicated by serial communication. Mode changes, however, must always be made on the front panel.

**Dimensions:**

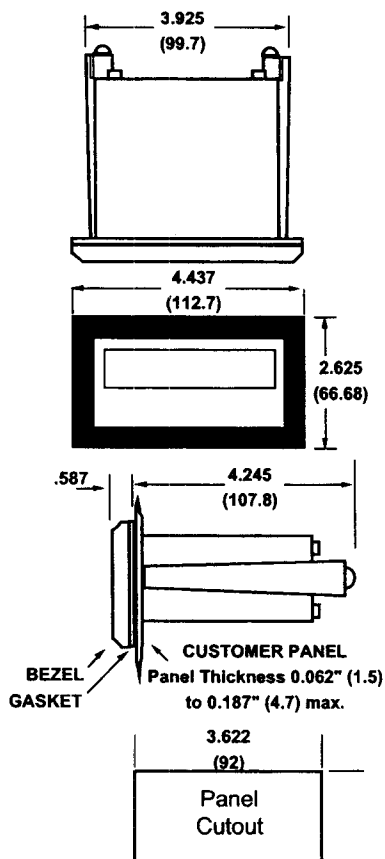

### Feed Batching Application

DPF10 Batch Controller

The DPF10 is the central controller for this feed batching application. The batcher is mounted on the dispensing truck and controls the dispensed amount of feed for each batch.

A sensor in the dispensing unit (auger or conveyer) sends pulses to the DPF10. This information is scaled by the batcher and displayed as pounds. The operator simply enters the amount of feed (in pounds) and presses the START key. Relay A energizes and sends power to the dispensing unit motor control. As the feed is dispensed, the DPF10 counts the pounds. Relay A drops out when the count reaches Preset (PRE A). The second counter is programmed to count the Grand Total. This allows the operator to keep track of the total amount of feed dispensed at each stop. The second counter may also be programmed as a Total Batch counter to keep track of the number of batches at each stop.

## MOUNTING

The unit is designed to be mounted with a gasket providing a water tight seal. Two mounting brackets are provided to secure the unit to the panel. A panel less than .1" may distort if the clamps are screwed too tightly.

Slide the body of the unit through the rubber gasket. Insert the unit into the panel. As shown in "FIG. A", slide the brackets up the groove to press against the back of the panel. Insert screws into rear of brackets and tighten them evenly and alternately. Do not over tighten! A normal level of torque is required. Maximum torque should be 3" pounds.

This product is designed to be panel mounted and is NEMA 4 rated if proper mounting procedures are followed and the required and supplied hardware is correctly used.

If the panel in which the unit is mounted is less than .125 of an inch thick, the possibility exists that there will be some flexing. Should this flexing occur, the resulting deformation of the panel could cause a loss of the water tight seal. In case this should occur, the use of silicone or other sealant would be recommended.

This product is designed to the NEMA 4 rated. However, the fact that we are unable to control either the location in which the device is installed or the actual installation itself requires that the company's liability shall extend only to the repair or replacement of a defective product.

We are prepared to offer additional assistance in those special situations where normal mounting methods do not seem to satisfy the customers needs. This assistance may be obtained by calling the factory and asking for Application Engineering.

**FIG. A**

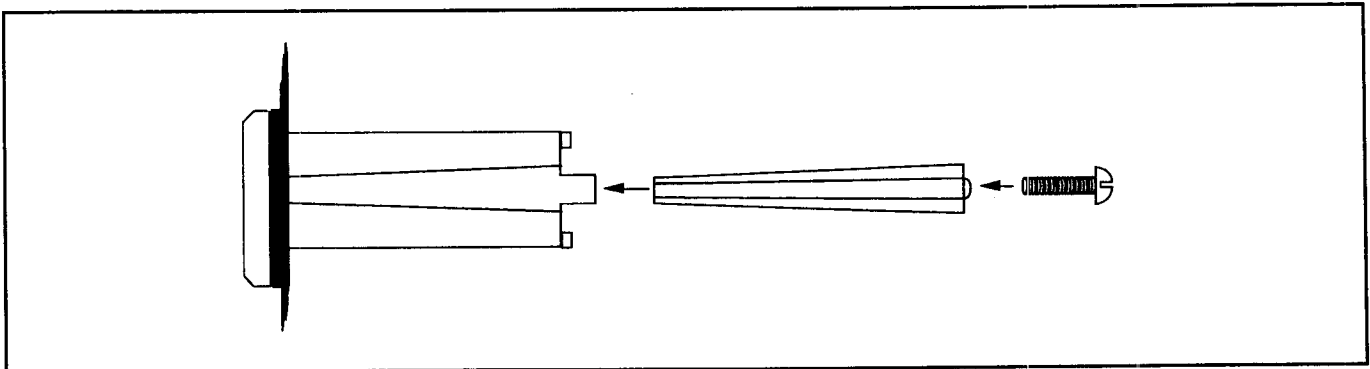

## DIMENSIONS

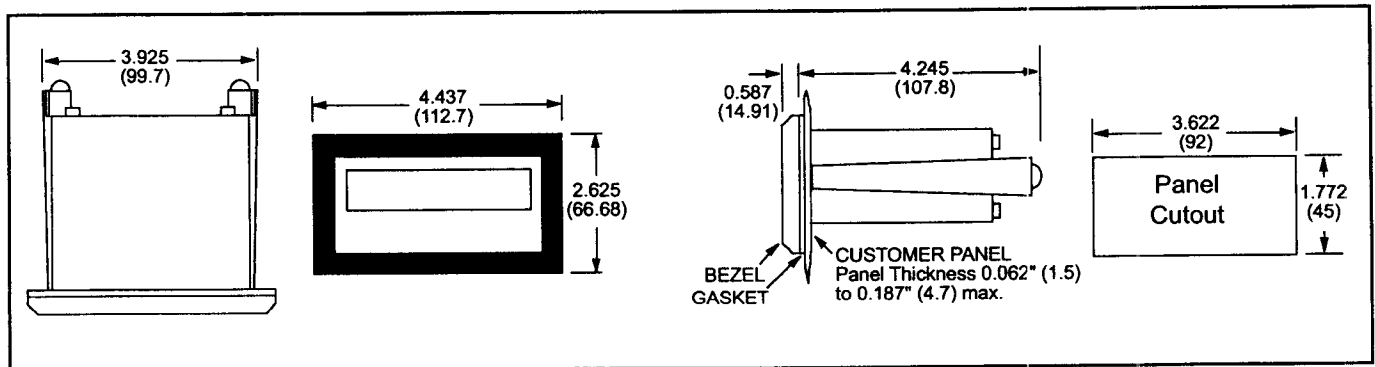

## WIRING

The rear terminal contains 12 screw terminals for connecting #14 to #28 gauge wire.

The unit is controlled by a microprocessor and, therefore, an electrically "noisy" environment could cause operating problems. The input power line should not be common to power lines for motors, pumps, contactors, etc.

The unit is designed to be immune from line or RF voltage interference. In some environments voltage spikes of over 100 volts, even 1000 volts, can occur. When common to a power line driving motors voltage fluctuations can be extreme and rapid. Lines driving DC or AC solenoids, relays, or actuators can also cause problems.

Four sources of noise can occur:

- 1) AC power line noise - If the unit cannot be connected to a clean power source, an inductive load suppressing device (MOV as GE # V130LA1 or Resistor Capacitor as Paktron # .2 uf/220 ohm @ 400V) can be installed. Although locating the suppressor across the AC supply at the unit should help, best results are obtained by connecting the suppressor across the leads of the "load" at the device causing the spike.
- 2) Input line noise -The noise is carried on the input and D.C. ground lines. Make sure the input wires are never run into the unit in a bundle with power input lines. Also, keep these input lines isolated from inductive lines from devices drawing heavy loads. If there is a possibility of electrical noise, we recommend using shielded cable, with the shield being hooked to the D.C. ground terminal on the instrument, and to "earth" at one point in the circuit, preferably at the D.C. ground terminal of the unit.
- 3) Output lines - The unit has two relay outputs. When these outputs are used to run external relays or solenoids, spikes can be generated upon activation. This noise can spread through the instrument causing operating problems. If the source is a D.C. operated device, a general purpose diode (IN4004) placed across the solenoid prevents electrical noise spikes. Connect the cathode (banded side) to the more positive side of the coil. If the source is an A.C. operated device, use a MOV or Resistor Capacitor across the coil.
- 4) 12 VDC output supply - Noise can be generated on the 12 VDC output supply if it is used to drive inductive loads or if the current draw exceeds 50 mA. Insure that all inductive loads have a diode (such as IN4004) across the coil and that the current does not exceed 50 mA.

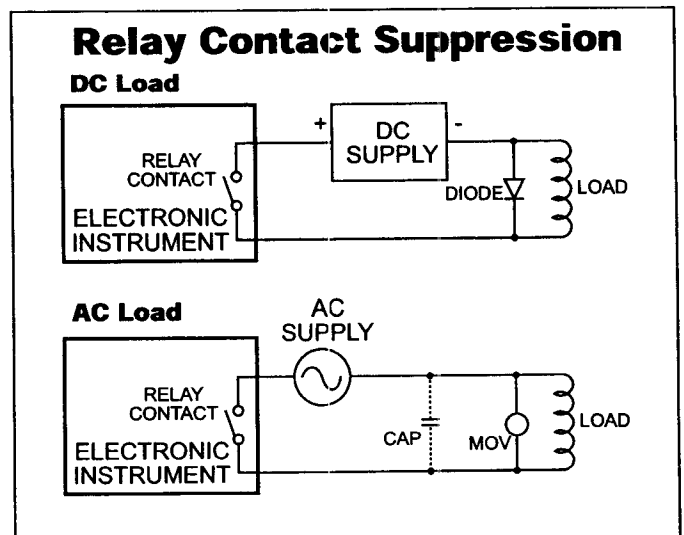
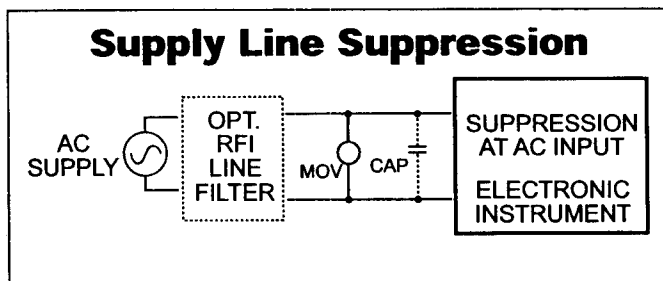

# WIRING (continued)

## AC / DC Power Connections

NOTE: Connect power only after other connections are finished. Do not touch the live AC power terminals! The unit has been designed with an isolated AC input. Thus, polarity is not a concern for the AC input. Connect AC power to pins 11 and 12. The chassis is plastic, therefore earth ground is not used. For D.C. operation, connect + 12V to pin 7 and - D.C. to pin 8.

## Sensor Connections

These diagrams show how to hook typical input sensors to the unit. The unit supplies an unregulated 12 Volt (50mA) output to power these sensors (Pin 7).

A valid pulse is one which makes a transition from the off-state (0 to 1V) to the on-state (4 to 30V): a positive going edge. The input impedance is 10K Ohms to ground. The unit can be programmed from the front panel for slow switch closure inputs up to 40Hz (select "Lo CPS"), or solid state switches (select "hi CPS") up to 9.99KHz. No rear terminal jumpers are required. Use PNP (sourcing) type pulsers.

## Wiring Terminations:

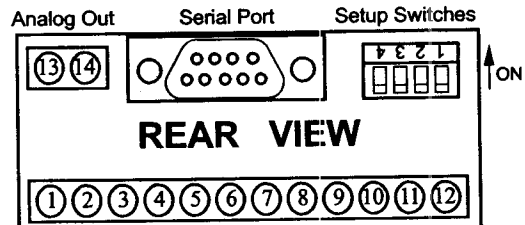
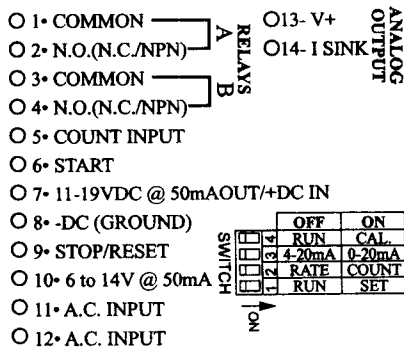

## Connecting the DPF10 to Omega Flowmeters & Amplifiers:

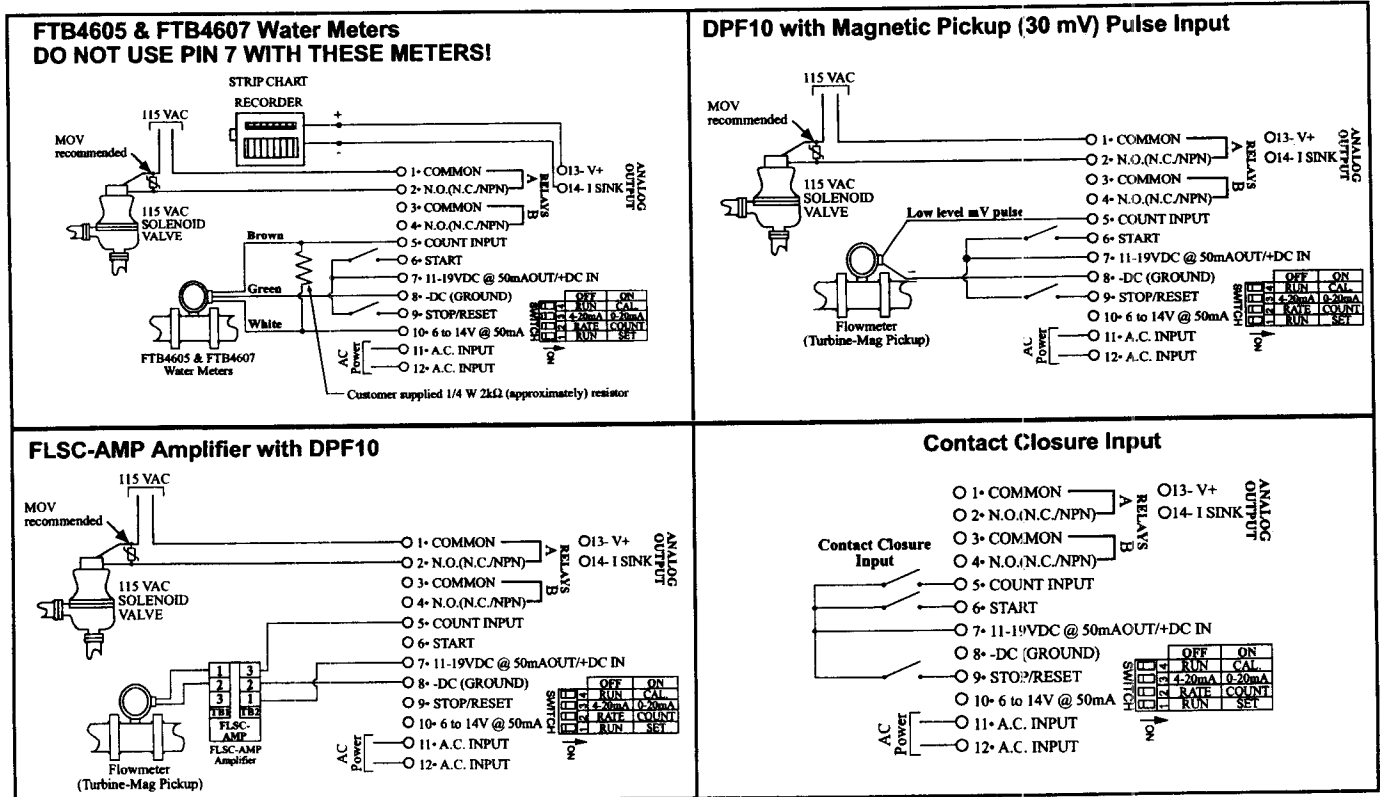



## THEORY OF OPERATION

### **Batching**

After the batcher has been programmed, it will operate as follows:

The unit will reset to "0" (count up mode) or load Preset A (count down mode) when RESET/STOP is activated. (front button or rear input)

When Start (front button or rear input) is activated, Relay A (and Relay B if Prewarn is selected) will energize and the right decimal will light. The unit will count in engineering units corresponding to the input scaling.

If Prewarn is selected for Relay B, Relay B will drop out when the count is at the selected number (Preset B) before final Preset A. When Preset A (or "0") is reached, Relay A drops out and the right decimal turns off. (The right decimal turns on whenever Relay A is energized). At the end of the batch the display is immediately loaded with "P" and Preset A number. At this point you can:

- Press START to reset and start another batch
- Press PRE A to change Preset A
- Press VIEW to view count (over-run)
- Press RESET/STOP to reset to "0" (Preset A)

If RESET/STOP is activated while the unit is started, Relay A (and Relay B if Prewarn) will drop out and the last count will remain on the display. Press START to continue the batch or RESET/STOP to abort the batch. All starts are inhibited if RESET/STOP is held active.

### **Grand Total or Batch Counter**

The second counter (displayed with inverted decimals) can be programmed as a Grand Total or Batch counter. The Grand counter counts the grand total, the Batch counter counts the total number of complete batches. These counters can only be reset from the front panel while viewing them. To reset, press the VIEW key until the displays shows a number with all decimals lit. Press RESET/STOP to reset.

### **Relay B Operation**

Relay B can be programmed as a prewarn relay or grand total/batch counter alarm.

When Relay B is set for Prewarn, Relay B will energize when the batcher is started. Relay B will drop out when the count is at the selected number (Preset B) before final Preset A. This is often used for slow down (2 stage batching).

When Relay B is set for total (Batch or Grand Total), Relay B will energize for the selected time duration when the Batch/Grand Total reaches Preset B. If the Relay is set to latch, it can be reset by resetting the Batch/Grand Total. (as described above).

### **Relay B as Scaled Pulse Output**

To use output B as a scaled output proceed as follows:

- 1) Select **Sr Tot** under **Count** section of menu.
- 2) Select **tot** under **RELAY** section of menu.
- 3) Enter the desired duration for the B Relay.
- 4) Set **PrEb** at desired scaling (**PrEb** is a divider).  
Maximum output frequency is 15 pulses/second.

### **Presets**

Preset A can be viewed and changed by pressing the "PRE A" button. The present Preset A will appear. Press buttons "A" through "E" to load in desired Preset A. Press the ENTER button once to enter.

Preset B can be viewed and changed by entering the program menu. Press the PRGM button. PRE B will appear. Press ENTER. The present Preset B will appear. Press buttons "A" through "E" to load in desired Preset B. Press the ENTER button once to enter.

### **VIEW Button**

The VIEW button allows you to alternately view:

1. Count of "A" (Batch)
2. Rate of "A" (Batching speed)
- 3.\* A) Grand Total if "Sr Tot" is selected  
B) Number of Batches if "br Tot" is selected

\* All decimal points are inverted when Grand/Batch Total is being displayed.

# INPUT & OUTPUT JUMPER SELECTIONS

## Output Jumper Selections

### Output Jumper Selections

Before making any board modifications, be sure power is disconnected and locate the plastic extender to the case at the rear of the unit. To remove the extender locate and remove the two screws which hold it in place. After the extender is removed the PC board will be exposed.

The unit must be removed from the case to access jumpers C & F, all other jumpers can be accessed by removing the plastic extender.

FUNCTION	MODIFICATION	
"A" RELAY N.C. OUTPUT	CUT AT "A"	JUMPER "B" TO "2"
"B" RELAY N.C. OUTPUT	CUT AT "D"	JUMPER "E" TO "4"
"A" PRESET TRANSISTOR (NPN)	CUT AT "A"	JUMPER "C" TO "2"
"B" PRESET TRANSISTOR (NPN)	CUT AT "D"	JUMPER "F" TO "4"

### BOTTOM VIEW AT TERMINAL

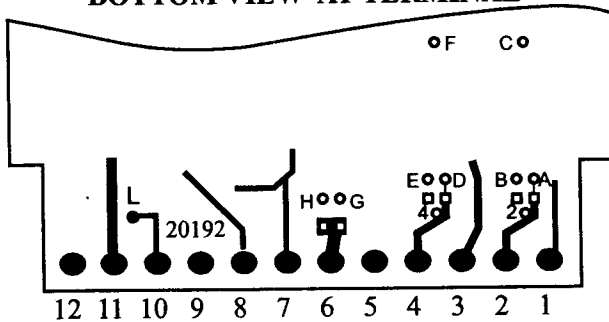

## Millivolt Input Option Jumper Selections

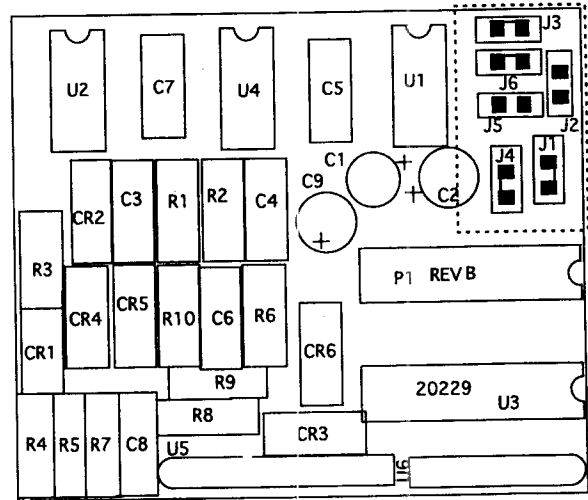

If the unit has the millivolt input bd.# 20229, the count input can be separately solder jumper programmed to accept either a low millivolt or 4-30 V input. Each unit shipped is programmed according to part number. If solder jumpers are made, the part number should be modified to reflect the changes made

C=CLOSE, O=OPEN

4-30V INPUT	Millivolt INPUT
J1-O, J2-C, J3-O	J1-C, J2-O, J3-C

# FRONT PANEL OPERATIONS

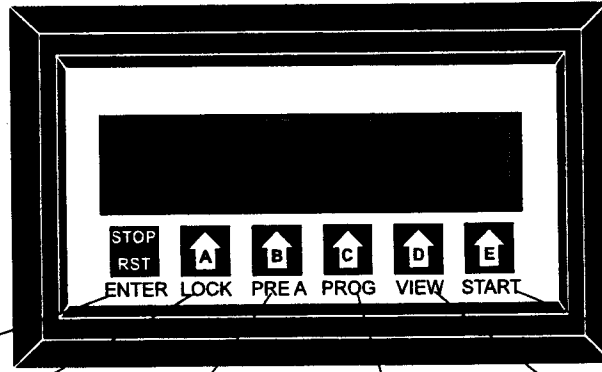

Press to STOP / RESET in operating mode; Press to "ENTER" in programming mode.

Press to "enter" LOCK code for panel lock.

Press to view or change Preset A

Press to cycle through PROGRAM choices; Press to step through set up choices in program mode.

Press to alternately view Rate, A Total or B Total

Press to Start

## PROGRAMMING FLOWCHART

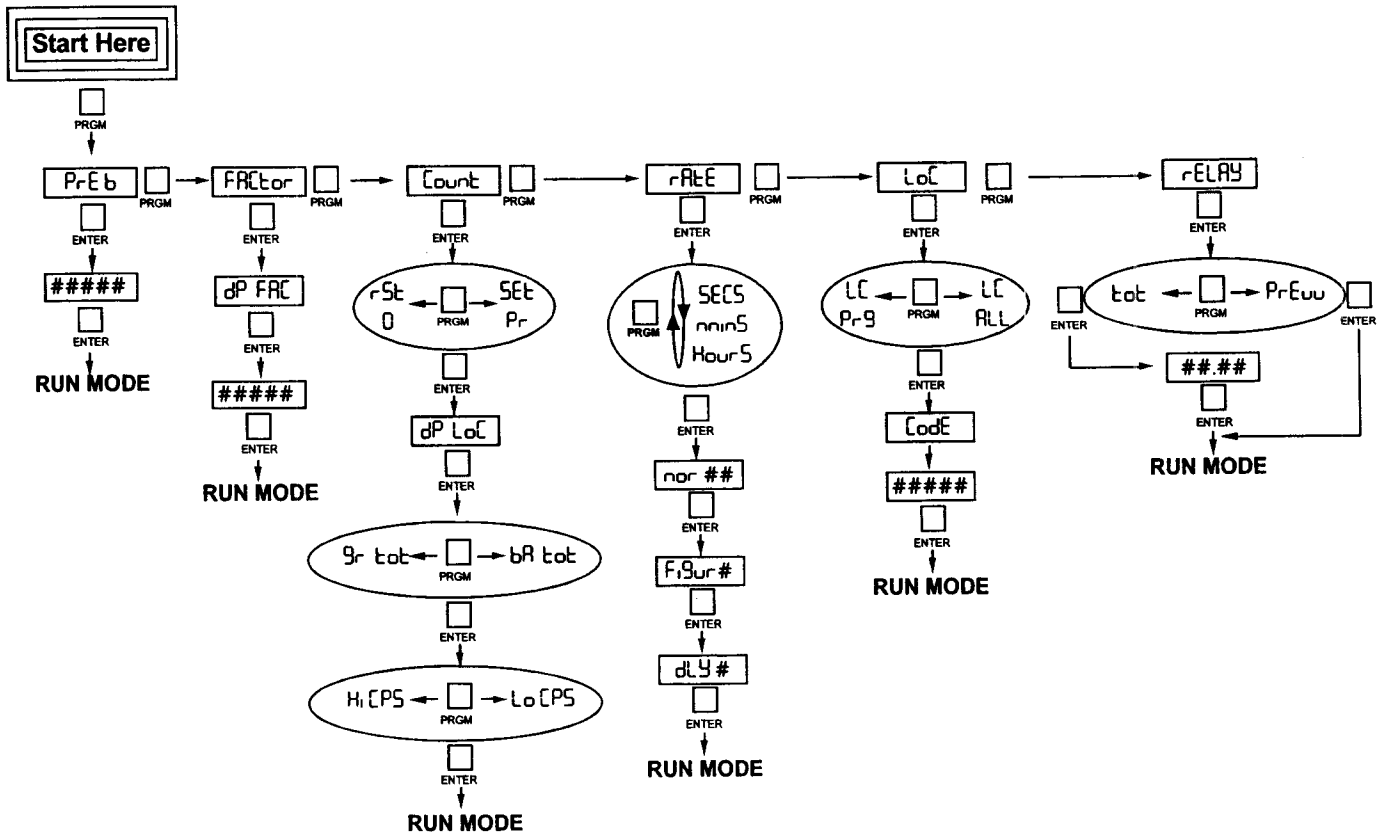

## DEFINITIONS OF MENU PROMPTS

The following is a list of abbreviations as they appear on the display and front panel of the unit.

<u>ABBREVIATION</u>	<u>DESCRIPTION</u>
PrEb	PRESET B - This is the setpoint for Relay B. Preset B can be used as a Prewarn or Grand/Batch Total alarm.
FRctbr	SCALING FACTOR - This portion of the menu is used to set the 5 digit dividing scale factor for the count input.
dPFR	DECIMAL POINT FOR FACTOR A - Enter location of decimal point for scaling Factor A by pressing the button under the digit where the decimal is desired.
Count	PORTION OF MENU FOR SETTING COUNTER VARIABLES
rSt0	RESET TO 0 - Counter will reset to 0. The Batcher will count up from 0.
SEtPr	SET TO PRESET - Counter will reset to preset A. The Batcher will count down from preset A.
dPLoC	DECIMAL POINT LOCATION - Enter desired location of decimal by pushing the button under the digit where the decimal is desired. Changing the decimal will change the decimal location in the counters, presets and rate display.
GrTot	GRAND TOTAL- This sets the second counter to count the Grand Total.
brTot	BATCH TOTAL- This sets the second counter to count the number of Batches.
HiCPS	HIGH COUNTS PER SECOND - This sets the unit for high count speeds (0-9.99 kHz)
LoCPS	LOW COUNTS PER SECOND - This sets the unit for contact debounce filtering (0-40 Hz)
rRE	PORTION OF MENU FOR SETTING RATE VARIABLES
SEC	SECONDS - The rate display will read in rate per second.
min5	MINUTES- The rate display will read in rate per minute.
Hour5	HOURS - The rate display will read in rate per hour.
nor##	NORMALIZING FACTOR - Normalizes (averages) the data being received. Higher settings provide more normalizing (averaging) for a more stable display. Derived from the equation: $\frac{(\text{Old Data} \times \text{"NOR"} + \text{New Data})}{(\text{"NOR"} + 1)}$
Figur##	SIGNIFICANT FIGURE - This sets the amount (1-5) of meaningful figures the unit will display. (RATE DISPLAY ONLY). FOR EXAMPLE: If "2" is set as the figure, a rate of 273.45 will be displayed as 270.

## DEFINITIONS OF MENU PROMPTS

(continued)

<u>ABBREVIATION</u>	<u>DESCRIPTION</u>
dLY##	DELAY FACTOR - The amount of time (02 to 24 sec.) the unit will "look" for valid data, before the display defaults to zero. (RATE DISPLAY ONLY)
LoC	LOCK - This portion of the menu allows you to set lock functions (Lock functions apply only to front panel) 1) lock the program (Preset A is still accessible) 2) lock all (locks program & presets; Start & Stop are accessible).
LC Pr9	LOCK PROGRAM - This will lock the program. Preset A can be changed, start, stop & reset will function when the unit is in the lock mode (lock ON).
LC ALL	LOCK ALL - This will lock the program and the presets when the unit is in the locked mode. Preset A can be viewed, but not changed. Start and Stop buttons will still operate.
LoC€	LOCK CODE - This message (code) will flash on display for approximately 3 seconds. It will be followed by a 5 digit number (xxxxx). The number you enter here will be the code to lock and unlock the unit.
rELRY	RELAY - This portion of the menu allows you to set your relay operation variables.
PrEuu	PREWARN - When this is selected Relay B energizes when started and drops out at "Preset B" amount before batch is complete.
tot	RELAY B FOR TOTALIZER - When this is selected relay B will activate when the selected Grand or Batch total has reached Preset B.
b##.##	RELAY B DURATION - This message will appear when "TOT" is selected. It is the duration which the relay will remain energized (00.01 to 99.99 sec). If 00.00 is selected, the relay will latch until reset. When the duration is not at 00.00, the Grand/Batch totalizer will autorecycle.

## CALCULATING SCALE FACTORS

The unit has a programmable scale factor to scale the input pulses. It is a 5 digit , floating decimal divider factor. The factor to enter is the number of pulses per the desired unit of measurement. The factor ranges from 0.0001 to 99999.

Scale factor calculations are simple. Here are some examples:

### DECIMAL LOCATION:

When a decimal is desired for display, special care must be taken when programming the Factor (FACTOR) and Decimal Location (dPLoC). The factor must be entered in pulses per units desired for display. (i.e. pulse per 1 unit, pulses per 0.1 units, pulses per 0.01 units, etc.) The Decimal Location (dPLoC) controls the decimal placement for the display. For each decimal place you move for dPLoC, you must also move the decimal for the factor (dPFR).

**Example:** The flow sensor outputs 678.4 pulses per gallon.  
 To display whole gallons (1 gal) enter 678.4 for the factor  
 To display tenths of gallons (0.1 gal) enter 67.84 for the factor  
 To display hundredths of gallons (0.01) gal) enter 6.784 for the factor

### SCALING FACTOR EXAMPLES:

**Flow Batching:** You want to fill a 55.0 gallon drum. The flow sensor gives 387 pulses per gallon.

**Solution -** Dial in a scale factor of 38.7 (38.7 to display 0.1 gal; 387 for whole gal.)  
 Under Count, set dPLoC to dPLoC to read tenths of gallons.  
 Set PRE A at 55.0; Wire Relay A to solenoid valve.

**Conveyer Batching:** You want to batch the amount of conveyer distance in feet. An inductive proximity sensor is used to sense a gear on a conveyer. The gear has 15 teeth (15 pulses per revolution). Each revolution of the gear equals 3 feet of conveyer movement. To find the number of pulses per foot, simply divide "15 pulse" by "3 feet" (15 ÷ 3 = 5).

**Solution -** There's 5 pulses/foot, enter 5 as the scale factor and the display will read in feet.  
 Set PRE A for the number of feet desired.  
 Wire Relay A to the conveyer RUN control.

### Converting Scale Factors

When different units of measure are given than what is desired, simply convert the given Scale Factors to reflect the desired units using the following calculations.

$$\frac{\text{Pulses Per Unit (given)}}{\text{Units Conversion Factor}} = \text{Scale Factor}$$

Use the Units Conversion Chart below when converting the given Scale Factor. Be sure to use the Scale Factor for whole units and divide it by the proper Conversion Factor.

UNITS CONVERSION CHART			
To convert:	divide factor by	To convert:	divide factor by
ft to m	0.3048	kg to lb	2.2046
ft <sup>2</sup> to m <sup>2</sup>	0.0929	l to ft <sup>3</sup>	0.0353
ft <sup>3</sup> to m <sup>3</sup>	0.02832	l to gal	0.2642
ft <sup>3</sup> to gal	7.4805	m to ft	3.2808
gal to l	3.7854	m <sup>2</sup> to ft <sup>2</sup>	10.7639
gal to m <sup>3</sup>	0.00379	m <sup>3</sup> to ft <sup>3</sup>	35.3147
gal to ft <sup>3</sup>	0.1337	m <sup>3</sup> to gal	264.172
gal to lb (H <sub>2</sub> O)	8.3378	lb to kg	0.45359

## PROGRAMMING

<b>STEP</b> 1	<b>PRESS</b>	<b>DISPLAY</b>	<b>REMARKS</b>
<b>SETTING PRESET B</b>	<input type="checkbox"/> PRGM	PrEb	This section of the menu is used to set Preset B value.
	<input type="checkbox"/> ENTER	#####	This is Preset B. To change, press the arrow key under the digit(s) to change. Press ENTER to enter the displayed value.

---

<b>STEP</b> 2	<b>PRESS</b>	<b>DISPLAY</b>	<b>REMARKS</b>
<b>SETTING SCALING FACTOR</b>	<input type="checkbox"/> PRGM	PrEb	This section of the menu is used to set up the scaling factor for the count input.
	<input type="checkbox"/> PRGM	FACtor	
	<input type="checkbox"/> ENTER	dP FAC	This sets the decimal for factor A. Press the arrow key under the digit where the decimal is desired. To clear the decimal, press the arrow key furthest to the right (PRGM).
<input type="checkbox"/> ENTER	#####	This is the scaling factor for the count input. To change, press the arrow key under the digit(s) to change. Press ENTER to enter the displayed value.	

---

## PROGRAMMING

(continued)

STEP  
3

SETTING  
THE  
COUNTER

<input type="checkbox"/> PRGM	PrEb	
<input type="checkbox"/> PRGM	FRctor	
<input type="checkbox"/> PRGM	Cunt	This section of the menu sets up the counter information.
<hr/>		
<input type="checkbox"/> ENTER	rSt 0 or SEt Pr	Press the PRGM key to choose RST 0 (reset to 0, count up) or SET PR (set to preset, count down), press the ENTER key to enter the displayed choice.
<hr/>		
<input type="checkbox"/> ENTER	dPlc	This sets the decimal location for the A & B counters. Press the arrow key under the desired digit location. To clear the decimal, press the arrow key furthest to the right. Press the ENTER key to enter the displayed location.
<hr/>		
<input type="checkbox"/> ENTER	Gr tot or bA tot	This section sets the second counter operation. Press the program key to choose GR TOT (Grand Total) or BA TOT (Batch Total). Press the ENTER key to enter the displayed choice.
<hr/>		
<input type="checkbox"/> ENTER	Hi CPS or Lo CPS	Press the PRGM key to choose HIGH CPS (0-9.99KHz) or LOW CPS (0-40Hz). Press the ENTER key to enter the displayed choice.



**PROGRAMMING**  
(continued)

STEP  
4  
SETTING  
THE RATE

<u>PRESS</u>	<u>DISPLAY</u>	<u>REMARKS</u>
<input type="checkbox"/> PRGM	PrEb	
<input type="checkbox"/> PRGM	FACtor	
<input type="checkbox"/> PRGM	Count	
<input type="checkbox"/> PRGM	rAtE	This section of the menu is used to set up the rate information.
<input type="checkbox"/> ENTER	SECS minS or HourS	Press the PRGM key to choose SECS (rate per second), minS (rate per minute) or HourS (rate per hour). Press ENTER to enter displayed choice.
<input type="checkbox"/> ENTER	nor ##	This sets the normalizing (averaging) factor. Press the arrow keys under the desired digits to change. Press ENTER to enter displayed value.
<input type="checkbox"/> ENTER	Figur #	This sets the number of significant figures to be displayed. Press the arrow key under the digit to change. Press ENTER to enter displayed value.
<input type="checkbox"/> ENTER	dLY ##	This sets the delay time (2 to 24 sec.) that the unit will "look" for valid input data before the display falls to 0. Press the arrow key under the digits to change. Press ENTER to enter displayed value.

**PROGRAMMING**  
(continued)

**STEP**  
**5**  
**SETTING**  
**LOCK**

<u>PRESS</u>	<u>DISPLAY</u>	<u>REMARKS</u>
<input type="checkbox"/> PRGM	PrEb	
<input type="checkbox"/> PRGM	FACtor	
<input type="checkbox"/> PRGM	Count	
<input type="checkbox"/> PRGM	rAtE	
<input type="checkbox"/> PRGM	LoC	This section of the menu is used to set up the lockout type and code number.

ENTER

LC PG  
or  
LC ALL

LC PG = Locks program but presets and reset are accessible. (see description)  
LC ALL= Locks all keypad buttons except START, STOP & VIEW.  
Press the PRGM button to toggle between choices; Press ENTER to enter displayed choice.

ENTER

CoDE  
Flashes  
followed by:  
####

After CODE flashes the display will show the existing lock code. To change the code press the key under each digit to be changed. Press ENTER to enter displayed value. (see below to turn lock ON or OFF)

**SETTING**  
**THE**  
**LOCK**  
**STATUS**

LOCK

CoDE  
Flashes  
followed by:  
0

Key in the lock code (see programming step 4) by pressing the keys under the digits to be changed. Press the ENTER key to enter the displayed code.

ENTER

LoC  
or  
unLoC

After the code is entered the unit will display LOC (unit is locked) or UN LOC (unit is unlocked). This message will be displayed for approximately 3 seconds before the unit returns to the run mode.

# PROGRAMMING

(continued)

**STEP**  
**6**

**SETTING**  
**THE**  
**RELAYS**

<u>PRESS</u>	<u>DISPLAY</u>	<u>REMARKS</u>
<input type="checkbox"/> PRGM	PrEb	
<input type="checkbox"/> PRGM	FRctor	
<input type="checkbox"/> PRGM	Count	
<input type="checkbox"/> PRGM	rAtE	
<input type="checkbox"/> PRGM	LoC	
<input type="checkbox"/> PRGM	rELAY	This section sets up the relay information.
<input type="checkbox"/> ENTER	tot or PREuu	Press the PRGM key to choose TOT (Relay B assigned to total) or PREW (Relay B assigned to prewarn). Press enter when the desired choice is displayed.
<input type="checkbox"/> ENTER	b##.##	This will only appear if tot selected. This is the duration (.01 to 99.99 sec) that relay B will remain energized. If 00.00 is selected, the relay will latch until reset.

**SETTING**  
**THE**  
**PRESETS**

<input type="checkbox"/> PRE A	PrER Followed by last PRE A entered	PRE A = Preset A (Batch Amount); The set point at which output A will drop out after started. If the displayed value is not the desired preset, press the key(s) under the digit to be changed.
<input type="checkbox"/> PRGM	PrEb	<p>PRE B = Preset B ;</p> <p>a) tot selected      The set point at which output B will energize.</p> <p>b) PREuu selected    The number of counts before batch ends that output B will drop out.</p>
If the displayed value is not the desired preset, press the key(s) under the digit to be changed.		

## RS 232 & RS422 INTERFACE CARD OPERATION

### **RS 232/422 SET-UP:**

All serial communication mode changes must be done through serial communications. Mode changes cannot be done through the front panel. To initialize the unit, place a jumper between pin 7(+12V)[bottom board] and pin 1(init)[DB -9 connector] on initial power up. The unit defaults to: 300 baud rate, "MARK" parity and device number 01. To enter the program mode you must set your terminal for 300 baud rate and "MARK" parity. Next, type D1(s), (s)= space bar. The unit will echo back "DEVICE #1:". Now type EP (enter program) and a carriage return (enter). The unit will echo back "PROGRAM SETTING". You are now in the programming mode.

### **SETUP PROCEDURE:**

The following sections consist of the communications setup options as they appear in the menu. (If you wish to exit the program mode, at any time you can hit the "escape key" (Hex Code: 1B) and the unit will save the changes made but not effect the remaining data values.) When each section of the setup menu is displayed, the current data will appear in the < > signs. If you wish to change the data, type in the number of the desired choice and press return (enter). If you wish to keep the current data, simply press return.

### **DEVICE NUMBER:**

Each unit in the hook-up must be assigned it's own device number (1 to 99). Zero is reserved for a dedicated hook-up to only one terminal, and it's transmit output line remains in an "on" active state. The device number is entered in the program mode. The unit will prompt you:

DEVICE# <XX>?

If XX is the desired device number press return (enter), if not enter the desired number after the question mark and press return (enter).

### **BAUD RATE:**

The baud rate is the speed at which data is transmitted, expressed in bits per second. Baud rates of 300, 600, 1200, 2400, 4800 or 9600 are available. When in the baud rate section of the menu, the unit will list :

BAUD RATES:

1:300 2:600 3:1200

4:2400 5:4800 6:9600

then prompt you:

BAUD RATE <300>?

Press return (enter) if this is the desired baud rate or enter the assigned number of one of the six possible baud rates. If an invalid baud rate is entered the unit will prompt you to choose another baud rate. This will occur until a valid baud rate is entered or escape is pressed.

### **PARITY:**

Parity is a bit of information that is inserted before the stop bit and is used to help check if the transmission is correct. When setting the parity you may select "ODD" (parity bit is logic 0 if total number of logic 1's in the first seven data bits is odd),

"EVEN" (parity bit is logic 0 if total number of logic 1's in the first seven data bits is even), "MARK" (parity bit is always logic 1 - High / Mark) or "SPACE" (parity bit is always logic 0 - Low / Space). If a "MARK" parity is chosen, it will appear that two stop bits are used. Use the "MARK" parity with terminals using parity "OFF" or "NONE". These terminals ignore the parity. The unit does not check the parity but does transmit the parity chosen. When setting the parity, the unit will print:

PARITIES:

MARK-0 SPACE-1 EVEN-2 ODD-3

Then the unit will prompt you:

PARITY<MARK>?

If this is the desired parity press return (enter), if it isn't enter the number of the desired parity then press return (enter).

### **STROBE LIST:**

The serial interface card is also equipped with a strobe line. When the strobe line is triggered, a chosen set of data will be transmitted to be displayed or printed. The selections for the display list are entered in the program mode. Enter "1" to add selections to the list and enter "0" to delete selections from the list. The six available items for the strobe display list are: (1) Preset A, (2) Preset B, (3) K-Factor A, (4) Rate of A, (5) Count A (Batch), (6) Grand / Batch Counter (Count B).

ENTER STROBE LIST:

DO NOT DISPLAY-0 DISPLAY-1

The unit will prompt you:

PRESET A<DISPLAY>?

PRESET B<DISPLAY>?

K-FACTOR A<DISPLAY>?

RATE<DISPLAY>?

COUNT A<DISPLAY>?

COUNT B<DISPLAY>?

If the above choices are entered, when the strobe line is triggered (3-30V positive pulse) the unit will transmit:

DEVICE# 1:

PA XXXXX

PB XXXXX

KA XXXXX

DR XXXXXX

DA XXXXXX

DB XXXXXX

(SEE COMMANDS BELOW FOR DESCRIPTION OF COMMAND CODES).

Each time the strobe line gets triggered the unit will transmit this data unless the program mode is entered and the strobe list altered.

After these four items have been entered they will remain unaltered unless the program mode is entered again and the values changed. The unit is now set and must be addressed by it's device number to come on line again.

**SERIAL INPUT COMMANDS:**

To get a unit on line you must address it by it's device number. This is done by typing DXX(S), XX= device number. The unit comes on line and echoes back DEVICE# XX. Insure that "DEVICE#XX:" is received before requests are sent. The unit is now ready to receive a command or string of commands separated by a space. A carriage return (enter) will enter the commands and processing of requests begins. The carriage return (Hex Code "D") puts the unit "off line" after data is processed.

**COMMANDS:**

- EP ..... Unit will enter program mode.
- DA ..... Unit will display (transmit) Count A.
- DB ..... Unit will display (transmit) Count B.
- DR ..... Unit will display (transmit) rate A.
- GO ..... Unit will START. (relays energize)
- ST ..... Unit will STOP if batch is in progress (relays drop out)
- KA ..... Unit will display K-factor A.
- †KA(S)XXXXX ..... Unit will load K-factor A with entered number.
- PA ..... Unit will display Preset A.
- †PA(S)XXXXX ..... Unit will load Preset A with entered number.
- PB ..... Unit will display Preset B
- †PB(S)XXXXX ..... Unit will load Preset B with entered number.
- RA ..... Counter A will reset
- †RA(S)XXXXXX ..... Unit will set Counter A to entered number.
- RB ..... Counter B will reset.
- †RB(S)XXXXXX ..... Unit will reset Batch / Grand Counter (Counter B) to entered number.

**\*THE UNIT WILL RECOGNIZE A DECIMAL IF ONE IS PLACED IN ANY OF THESE DATA VALUES.**

**†THE UNIT WILL ONLY RECOGNIZE THE LAST FIVE DIGITS ENTERED (SIX DIGITS FOR RA & RB). IF A NEGATIVE SIGN IS PRESENT, IT WILL NOT BE CHANGED.**

The following is an example of requests and responses:

<u>Transmit from terminal</u>	<u>Receive from unit</u>
	(s)=Space
D5(s) [Unit #5 Activated]	DEVICE# 5:
PA(s)12345(s)PA	PA 12345 PA
KA(s)1576(s)KA	KA 1576 KA
RA(s)RB[RETURN]	RA RB

(UNIT PRESETS AND A K-FACTOR ARE SET AND BOTH COUNTERS ARE RESET)

12345

1576

**SERIAL INTERFACE OPERATION:**

Data is received and transmitted over standard EIA RS232 or RS422 levels. Each ten bit character is made up of a start bit, seven bit ASCII code, a parity bit and a stop bit. Device number, baud rate, parity and strobe list are entered in the program setup mode and will remain in memory even if power is lost.

The input impedance of RS232 is 3KΩ to 7KΩ worst case. The terminal addressing the unit must be capable of driving all loads in the loop. The input impedance of RS422 is much higher and there should be no problem driving as many as 99 units. The transmit line remains in a high impedance "off" state until addressed. Only one unit is to be on line at a time!!! More than one unit on line could damage the unit or destroy the transmitted data.

When the unit is active (on line) it will operate in a full duplex, echo back mode, so that data sent from the terminal will be transmitted back for verification. When the unit is "on line", use the proper serial transmit commands to request data or set a new value. Up to 80 characters of data can be linked together and transmitted to the unit in a string as long as there is a space between the commands. If an error is made, a correction can be made by back spacing and retyping correct data before the return (enter) is sent. Once a return (enter) is sent, the unit begins processing the data and will transmit the requested data on a non-priority basis over the data transmit line. A keypad entry or incoming data will halt the data communication cycle. Therefore, there should be a pause after data is requested to insure that all data has been transmitted before making another request or addressing another unit. If the unit is not busy, it should not take longer than 300 msec to process each request. To find the cycle time to process and transmit a request, calculate the bit transmit time by using this formula: [(1+ baud rate) x (80) + .005] x number of requests made. This time will be extended if the unit must service the front keypad. If transmission has not started within two seconds after data is requested, it can be assumed that there is a problem. The unit transmits a carriage return and line feed after each data value. Any new communication must be started with DXX(S) (device number and space).

**RS232/RS422 - IBM-PC INTERFACE:**

The following program is for IBM basic to set up RS232/RS422 on serial port (#1) at 300 baud. Run this program after connecting the serial interface connections.

```

10 SCREEN 0,0:WIDTH 80
20 CLS:CLOSE
30 OPEN "COM1:300,n,7,1,CS,DS,CD" AS #1
40 ON ERROR GOTO 110
50 B$=INKEY$
60 IF B$< >" THEN PRINT #1,B$;
70 IF EOF (1) THEN 50
80 A$=INPUT$ (LOC(1),#1)
90 PRINT A$;
100 GOTO 50
110 RESUME

```

## RS232 & RS422 WIRING

### RS232 / RS422 Connector:

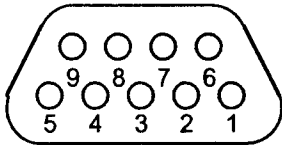

#### RS 232

1. INITIALIZE
2. TRANSMIT
3. RECEIVE
4. N/C
5. GROUND
6. STROBE
7. N/C
8. N/C
9. N/C

#### RS 422

1. INITIALIZE
2. TRANSMIT A (+)
3. RECEIVE A (+)
4. N/C
5. GROUND
6. STROBE
7. TRANSMIT B (-)
8. RECEIVE B (-)
9. N/C

### Computer Hookup:

**RS 232:** When connecting the unit to a computer with RS 232 communication, only three connections are needed. These connections are: Receive data, Transmit data and Ground. The connections should be made as follows:

**RS 422:** When connecting the unit to a computer with RS 422, five connections are needed. These connections are: Receive data A (+), Receive data B (-), Transmit data A (+), Transmit data B (-) and Ground. The connections should be made as follows:

#### DP -9 CONNECTOR

Transmit data (pin 2)  
Receive data (pin 3)  
Ground (pin 5)

#### COMPUTER

Receive data  
Transmit data  
Ground

#### DP -9 CONNECTOR

Transmit data A(+) (pin 2)  
Transmit data B(-) (pin 7)  
Receive data A(+) (pin 3)  
Receive data B(-) (pin 8)  
Ground (pin 5)

#### COMPUTER

Receive data A(+)  
Receive data B(-)  
Transmit data A(+)  
Transmit data B(-)  
Ground

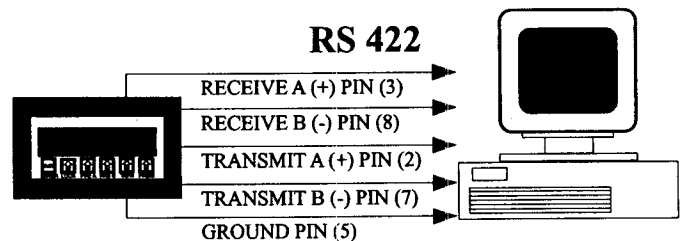
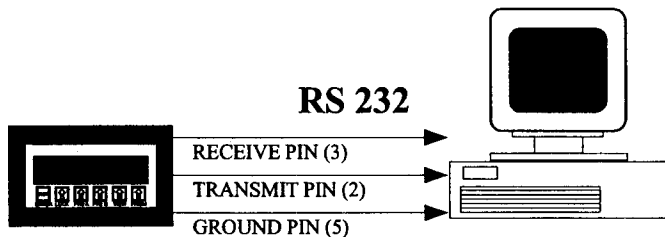

### Printer Hookup:

When connecting the unit to a printer, you must first program the desired baud rate, parity and strobe list with a computer. After the unit is programmed it can be connected to the printer. Connect the transmit line(s) of the unit to the receive line(s) of the printer and be sure that both devices have common grounds. When the strobe line is triggered the unit will transmit the selected strobe list which you had previously programmed.

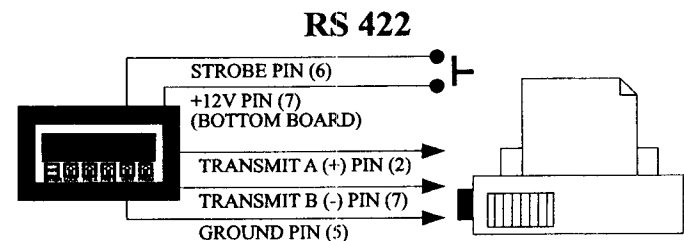
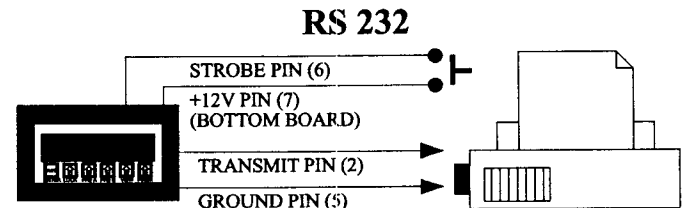

# ANALOG OUTPUT OPTION

**Description:**

An optional 4-20mA (0-20mA) output has been added to the Minitrol series. The output can be programmed to track rate or total. This feature is available by adding suffix A to the part number. Connections are via a 2 terminal pluggable screw connector.

**Connections:** (see FIG. 1)

PIN13 supplies the 12 to 18 VDC to power the current loop.  
PIN14 is the control sink driver

**Accuracy:**

50uA worst case

**Compliance Voltage:**

3 to 30 VDC non conductive

**Setup:**

The optional analog output feature uses 4 dip switches on the back for setup. These switches are used as follows:

**SW1** - View or change "set low" and/or "set high" values

**SW2** - Select output for rate or total

**SW3** - Select 4-20mA or 0-20mA

**SW4** - Calibrate the unit.

After the regular parameters shown in the programming flowchart have been set, locate the 4 switches on the back of the unit. (see FIG. 1)

**Switch Settings:**

**SWITCH 1: Enter Analog Low & High** (normally off)

Switch 1 is used to load in the low (4mA or 0mA) and/or the high (20mA) output settings. With power on, set switch 1 ON (up).

LOW SETTING is viewed or changed by pressing PRE A. If the displayed value is correct, press ENTER. If not, press buttons A through E to step to the desired value and press ENTER. (disregard the display which will show the last count reading).

HIGH SETTING is viewed or changed by pressing PRE B. If the displayed value is correct, press ENTER. If not, press buttons A through E to step to desired value and press ENTER.

Return switch 1 to OFF (down) position, PRE A and PRE B buttons now function to view or change relay trip values.

**SWITCH 2: Select Count or Rate**

SW2 OFF (down): Analog output follows rate  
SW2 ON (up): Analog output follows count

**SWITCH 3: Select 4-20mA or 0-20mA**

SW3 OFF (down): Selects 4-20mA output range  
SW3 ON (up): Selects 0-20mA output range

**SWITCH 4: Calibrate** (normally off)

Switch 4 is used for calibration. Calibration is done at the factory and should not be needed (see SWITCH 1 to enter high and low values). If recalibration is desired, a calibrated 20mA ammeter with 1uA resolution is needed. Attach the "+" lead of the meter to pin 13 and the "-" lead to pin 14. Set switch 4 ON (up). The unit will output approximately 20.000mA and a decimal will light in the third position. Read the output using the ammeter. Press PRE A. If the display is the same as the ammeter reading, press ENTER. If not, press buttons A through E to step to ammeter reading and ENTER. (Disregard display which now shows the last count reading with decimal point in third position) Return switch 4 to OFF (down) position.

**RS232 & RS422 Operation:**

When the unit is supplied with RS232 or RS422, the analog output "low" and "high" settings can be accessed and changed through the serial port. The codes are as follows:

**AL** Unit will display (transmit) analog out "low" value.

**AL(S)XXXX** Unit will load analog out "low" with entered number. (S) = space

**AH** Unit will display (transmit) analog out "high" value.

**AH(S)XXXX** Unit will load analog out "high" with entered number. (S) = space

FIG. 1

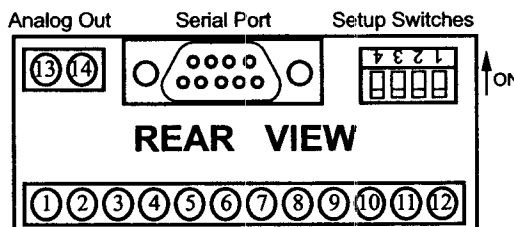

**Typical Wiring:**

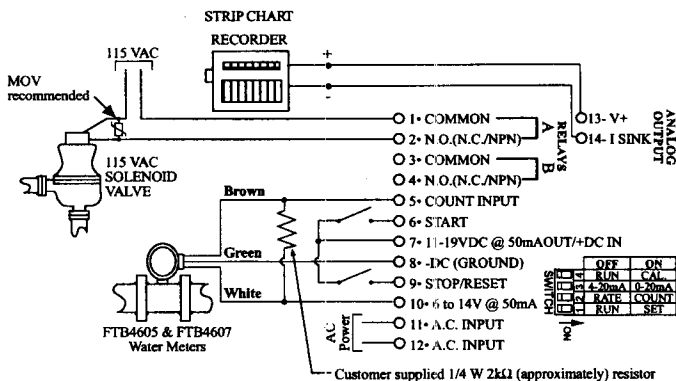

## TROUBLESHOOTING GUIDE

<u>PROBLEM</u>	<u>POSSIBLE CAUSES</u>	<u>SOLUTIONS</u>
Power is applied to unit but the display does not light.	1. AC or DC power wiring is incorrect.	1. Recheck power wiring
Unit works, but occasionally the display freezes or skips counts.	1. Line noise is affecting the processor due to a current spike or surge.	1. Use a different power supply or install a surge suppressor.
Input signal is connected but the unit does not count or display rate.	1. Input wiring is incorrect. 2. Scale factors are incorrect. 3. Transmitting device is defective. 4. Wrong debounce filtering selected. 5. Batcher is defective.	1. Recheck input wiring. 2. Recheck scale factors and factor calculations. 3. Replace transmitting device. 4. Recheck debounce filtering selection "hi cps" or "lo cps". 5. To confirm set scale factor at one and connect a wire to pin #7 and touch it to pin # 5 (input A). Each time pin #5 is touched counter A should count once. If not, call factory for RMA.
Rate is displaying: r FFFFF.	1. The unit is trying to display a number which it can't (too small or too large). 2. Line noise affected unit on power up.	1. Check scaling factor, if it is correct, lower the number of significant figures. 2. Reprogram the unit and be sure to enter a decimal (enter one and re move it if a decimal is not desired).
Relays are not activating properly.	1. START not activated. 2. Wrong relay duration. 3. Relay set for wrong activation i.e. EOL instead of PrEUL.	1. Relay A (and B if Prewarn) will only energize when start is activated. 2. Recheck programmed relay duration. 3. Recheck programmed relay activation mode.
Grand / Batch Counter resets before reaching 999999.	1. Relay duration is set at a value other than 00.00. This causes the counter to auto-reset at the preset.	1. If Relay B output is not being used, set the relay duration to 00.00.
Various menu items are not being displayed.	1. The menu flow chart and the setup steps show the setup for units with all of the available options. Options not ordered will be suppressed in the programming menu.	1. Disregard any menu items which appear on the flowchart and setup steps, but do not appear on the unit's display.





## WARRANTY/DISCLAIMER

OMEGA ENGINEERING, INC. warrants this unit to be free of defects in materials and workmanship for a period of **13 months** from date of purchase. OMEGA's WARRANTY adds an additional one (1) month grace period to the normal **one (1) year product warranty** to cover handling and shipping time. This ensures that OMEGA's customers receive maximum coverage on each product.

If the unit malfunctions, it must be returned to the factory for evaluation. OMEGA's Customer Service Department will issue an Authorized Return (AR) number immediately upon phone or written request. Upon examination by OMEGA, if the unit is found to be defective, it will be repaired or replaced at no charge. OMEGA's WARRANTY does not apply to defects resulting from any action of the purchaser, including but not limited to mishandling, improper interfacing, operation outside of design limits, improper repair, or unauthorized modification. This WARRANTY is VOID if the unit shows evidence of having been tampered with or shows evidence of having been damaged as a result of excessive corrosion; or current, heat, moisture or vibration; improper specification; misapplication; misuse or other operating conditions outside of OMEGA's control. Components which wear are not warranted, including but not limited to contact points, fuses, and triacs.

**OMEGA is pleased to offer suggestions on the use of its various products. However, OMEGA neither assumes responsibility for any omissions or errors nor assumes liability for any damages that result from the use of its products in accordance with information provided by OMEGA, either verbal or written. OMEGA warrants only that the parts manufactured by it will be as specified and free of defects. OMEGA MAKES NO OTHER WARRANTIES OR REPRESENTATIONS OF ANY KIND WHATSOEVER, EXPRESS OR IMPLIED, EXCEPT THAT OF TITLE, AND ALL IMPLIED WARRANTIES INCLUDING ANY WARRANTY OF MERCHANTABILITY AND FITNESS FOR A PARTICULAR PURPOSE ARE HEREBY DISCLAIMED. LIMITATION OF LIABILITY: The remedies of purchaser set forth herein are exclusive, and the total liability of OMEGA with respect to this order, whether based on contract, warranty, negligence, indemnification, strict liability or otherwise, shall not exceed the purchase price of the component upon which liability is based. In no event shall OMEGA be liable for consequential, incidental or special damages.**

CONDITIONS: Equipment sold by OMEGA is not intended to be used, nor shall it be used: (1) as a "Basic Component" under 10 CFR 21 (NRC), used in or with any nuclear installation or activity; or (2) in medical applications or used on humans. Should any Product(s) be used in or with any nuclear installation or activity, medical application, used on humans, or misused in any way, OMEGA assumes no responsibility as set forth in our basic WARRANTY/DISCLAIMER language, and, additionally, purchaser will indemnify OMEGA and hold OMEGA harmless from any liability or damage whatsoever arising out of the use of the Product(s) in such a manner.

## RETURN REQUESTS/INQUIRIES

Direct all warranty and repair requests/inquiries to the OMEGA Customer Service Department. BEFORE RETURNING ANY PRODUCT(S) TO OMEGA, PURCHASER MUST OBTAIN AN AUTHORIZED RETURN (AR) NUMBER FROM OMEGA'S CUSTOMER SERVICE DEPARTMENT (IN ORDER TO AVOID PROCESSING DELAYS). The assigned AR number should then be marked on the outside of the return package and on any correspondence.

The purchaser is responsible for shipping charges, freight, insurance and proper packaging to prevent breakage in transit.

FOR **WARRANTY** RETURNS, please have the following information available BEFORE contacting OMEGA:

1. Purchase Order number under which the product was PURCHASED,
2. Model and serial number of the product under warranty, and
3. Repair instructions and/or specific problems relative to the product.

FOR **NON-WARRANTY** REPAIRS, consult OMEGA for current repair charges. Have the following information available BEFORE contacting OMEGA:

1. Purchase Order number to cover the COST of the repair,
2. Model and serial number of the product, and
3. Repair instructions and/or specific problems relative to the product.

OMEGA's policy is to make running changes, not model changes, whenever an improvement is possible. This affords our customers the latest in technology and engineering.

OMEGA is a registered trademark of OMEGA ENGINEERING, INC.

© Copyright 2002 OMEGA ENGINEERING, INC. All rights reserved. This document may not be copied, photocopied, reproduced, translated, or reduced to any electronic medium or machine-readable form, in whole or in part, without the prior written consent of OMEGA ENGINEERING, INC.

# Where Do I Find Everything I Need for Process Measurement and Control? **OMEGA...Of Course!**

***Shop online at [www.omega.com](http://www.omega.com)***

## **TEMPERATURE**

- Thermocouple, RTD & Thermistor Probes, Connectors, Panels & Assemblies
- Wire: Thermocouple, RTD & Thermistor
- Calibrators & Ice Point References
- Recorders, Controllers & Process Monitors
- Infrared Pyrometers

## **PRESSURE, STRAIN AND FORCE**

- Transducers & Strain Gages
- Load Cells & Pressure Gages
- Displacement Transducers
- Instrumentation & Accessories

## **FLOW/LEVEL**

- Rotameters, Gas Mass Flowmeters & Flow Computers
- Air Velocity Indicators
- Turbine/Paddlewheel Systems
- Totalizers & Batch Controllers

## **pH/CONDUCTIVITY**

- pH Electrodes, Testers & Accessories
- Benchtop/Laboratory Meters
- Controllers, Calibrators, Simulators & Pumps
- Industrial pH & Conductivity Equipment

## **DATA ACQUISITION**

- Data Acquisition & Engineering Software
- Communications-Based Acquisition Systems
- Plug-in Cards for Apple, IBM & Compatibles
- Datalogging Systems
- Recorders, Printers & Plotters

## **HEATERS**

- Heating Cable
- Cartridge & Strip Heaters
- Immersion & Band Heaters
- Flexible Heaters
- Laboratory Heaters

## **ENVIRONMENTAL MONITORING AND CONTROL**

- Metering & Control Instrumentation
- Refractometers
- Pumps & Tubing
- Air, Soil & Water Monitors
- Industrial Water & Wastewater Treatment
- pH, Conductivity & Dissolved Oxygen Instruments