

INDUSTRIAL FLOW SWITCHES

From 2 to 15 ft/s

FSW-40A/ FSW-50 Series



- ✓ Rugged Industrial Design
- ✓ Switch Point Adjustable While Unit is Operating
- ✓ 15 A SPDT Switch Directly Controls Pump
- ✓ Mounts in Any Position

The FSW-40A and FSW-50 Series flow switches feature 15 A SPDT switches and an internal screw adjustment for in-line monitoring of switch points. Multiple drag disks provide incremental switch point adjustment. Their non-magnetic design makes these switches ideal for applications in which rust is a problem. The FSW-40A Series has a brass and stainless steel construction, while the FSW-50 Series comes in a plastic/316 SS construction.

The FSW-40A Series is ideal for machine-cutting oils and for sewage applications in which large objects are not caught on the drag disks. Installation "T" fittings are recommended for installing switches for 2" pipe size and below. For other pipe sizes, a "tee" fitting or weld coupling can be used.

SPECIFICATIONS

Relay Switch: SPDT 15 A @ 125 or 250 Vac; 10,000,000 operations median
Nominal Sensitivity (% Flow Change to Activate Switch):

10% @ upper end of range;
30% @ lower end of range

Pressure Drop: 1 to 3" pipe, less than 1 psi; 4" and above, negligible

Maximum Pressure/Temperature:

FSW-40A Series: 300 psig @ 82°C (180°F)

FSW-50 Series: 100 psig @ 93°C (200°F)

Minimum Temperature: 4°C (40°F)

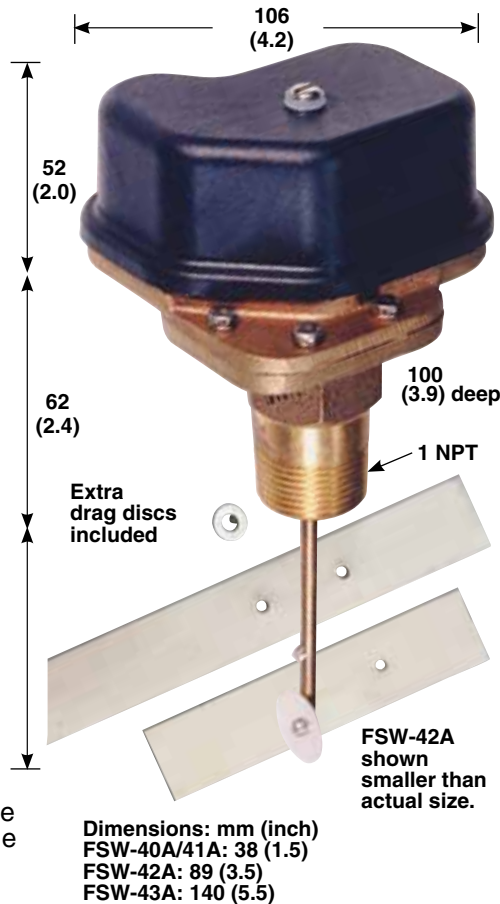

Wetted Parts:

FSW-40 Series: Red brass, 316 SS, phosphor bronze and EPDM and cork rubber (other materials are brass body, Noryl® cover, 316 SS hardware)

FSW-50 Series: Polyphenylene sulfide, 316 SS, FKM; also available with polyphenylene sulfide, Hastelloy C and FKM construction

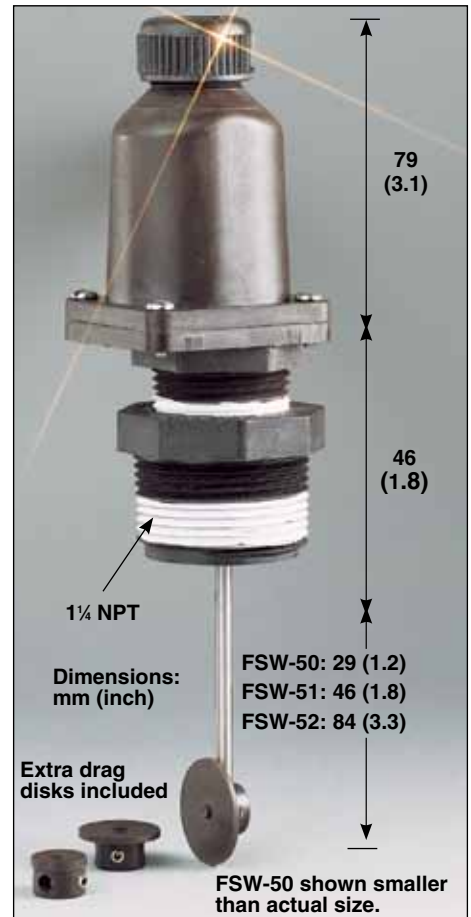

Electrical Cable Fitting:

Water resistant for cable diameters 0.250 ±0.025"

Weight:

FSW-40A Series: 1.59 kg (3.5 lb)

FSW-50 Series: 179 g (6 oz)

To Order

Model No.	No. of Extra Disks Included	For Pipe Sizes	Switch Point Adjustment Range (fps)	
			Low	High
FSW-40A	1	1"	2.0 to 6.0	5.0 to 15.0
FSW-41A	2	1½ to 2½"	2.0 to 6.0	5.0 to 15.0
FSW-42A	3	3 to 10"	2.0 to 6.0	5.0 to 15.0
FSW-43A	3	10 to 48"	2.0 to 6.0	5.0 to 15.0
FSW-50	1	1"	3.3 to 5.3	7.4 to 11.5
FSW-51	1	1½ to 2½"	2.7 to 5.4	5.4 to 10.8
FSW-52	1	3 to 10"	2.0 to 4.0	4.0 to 8.0

Comes complete with operator's manual.

For FSW-40A series with 316 SS, FKM and PTFE special construction, add suffix "-SS" to model number, for additional cost. For FSW-50 series with polyphenylene sulfide Hastelloy C and FKM special construction, add suffix "-HST" to model number, for additional cost.

Ordering Examples: FSW-40A-SS, FSW-40A flow switch with special 316 SS, FKM and PTFE construction.

FSW-52, flow switch for 3 to 10" pipe.