

1 YEAR
WARRANTY

Ω OMEGA® **User's Guide**

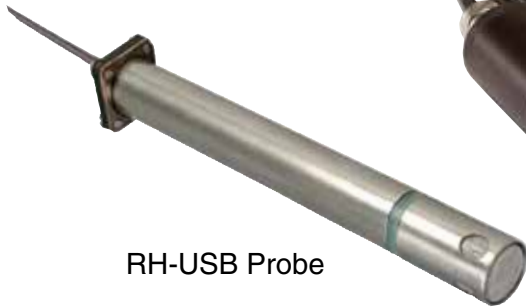

RH-USB Probe



IR-USB

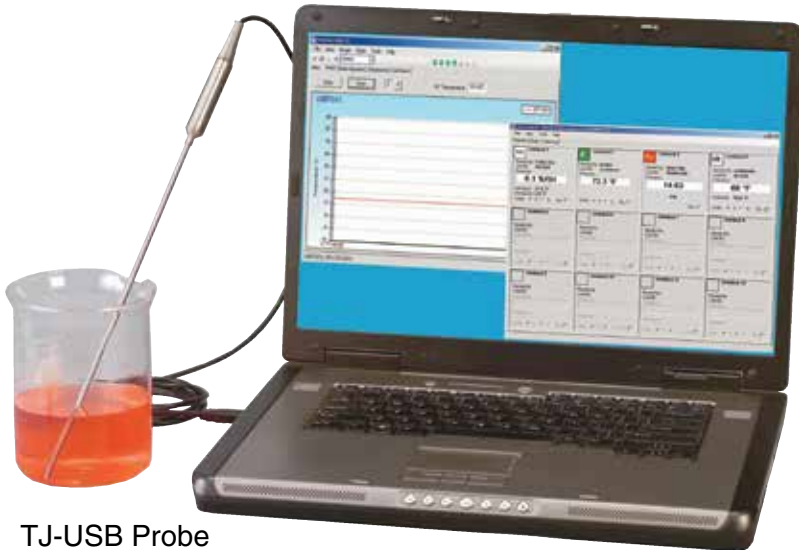

TJ-USB Probe

***Shop online at
omega.com®***
e-mail: info@omega.com
***For latest product manuals:
www.omegamanual.info***



PX409-USB



UTC-USB Connector

USB SERIES **Probes, Sensors, Connectors, and** **Pressure Transducers**



omega.com info@omega.com

Servicing North America:

**U.S.A.
Headquarters:**

Omega Engineering, Inc.

Toll-Free: 1-800-826-6342 (USA & Canada only)

Customer Service: 1-800-622-2378 (USA & Canada only)

Engineering Service: 1-800-872-9436 (USA & Canada only)

Tel: (203) 359-1660

Fax: (203) 359-7700

e-mail: info@omega.com

For Other Locations Visit omega.com/worldwide



Table of Contents

Section	Page
Section 1 Introduction	1-1
1.1 Precautions	1-1
1.2 Safety Warnings and IEC Symbols	1-1
1.3 Statement on Marking	1-2
1.4 General Description	1-2
Section 2 Hardware	2-1
2.1 Package Inspection	2-1
2.2 Included Items	2-1
2.3 IR-USB Accessories	2-1
2.3.1 IR-USB Accessories Dimensions	2-2
2.3.2 Laser Sighting Accessory Operation	2-4
Section 3 Software	3-1
3.1 Getting Started	3-1
3.2 Software Installation Requirements	3-1
3.3 Software Installation	3-1
3.4 TRH Central Measurement and Recording Program	3-6
3.4.1 Main Tab Menu	3-6
3.4.2 Channel Configuration	3-7
3.5 Chart Tab	3-8
3.6 Data Log Tab	3-12
Section 4 Specifications	4-1
Section 5 Emissivity Table (For IR-USB Models)	5-1



Table of Figures

Figure	Description	Page
Section 1 Introduction		
1-1	IEC Symbols	1-1
1-2	TJ-USB Overall Dimensions	1-2
1-3	RH-USB Dimensions	1-2
1-4	UTC-USB Dimensions	1-3
1-5	PX409-USB Dimensions	1-3
1-6	IR-USB Dimensions	1-3
Section 2 Hardware		
2-1	Mounting Bracket, OS100-MB	2-2
2-2	Water Cooling Jacket, OS100-WC	2-3
2-3	Typical Water Cool Jacket Assembly	2-3
2-4	Air Purge Collar, OS100-AP.....	2-3
2-5	Laser Sighting Accessory, OS100-LS	2-4
2-6	Laser Warning Label	2-5
Section 3 Software		
3-1	Welcome Screen	3-1
3-2	Install Options Screen	3-2
3-3	Select Install Folder Screen	3-2
3-4	License Agreement Screen	3-3
3-5	Confirm Installation Screen	3-3
3-6	Welcome to the Device Driver Installation Wizard Screen	3-4
3-7	Device Driver Installation Wizard Screen	3-4
3-8	Completing the Device Driver Installation Wizard Screen	3-5
3-9	Installation Complete Screen	3-5
3-10	Channel Tab Screen	3-6
3-11	TRH Central Program Screen	3-6
3-12	Channel Configuration Screen.....	3-7
3-13	Chart TAB Menu Screen	3-8
3-14	Charting Screen	3-8
3-15	Start Data Logging/Plotting Screen	3-9
3-16	Configure Axis Screen	3-10
3-17	Charting Options Screen	3-10
3-18	Data Log TAB Screen	3-12
3-19	Data Logging Screen	3-13
3-20	Start Data Logging/Plotting Screen	3-13
Section 4 Specifications		
4-1	Optical Field of View	4-1

Section 1 - Introduction

Please read this manual completely before installing and operating your USB based probe, connector, or pressure transducer.

It's important to read and follow all notes, cautions, warnings and safety precautions before operating this device.

1.1 Precautions

- This device is not designed for use in medical or nuclear applications.
- Do not operate this device in flammable or explosive environments.
- Do not operate this device outside of the recommended use outlined in this manual.

NOTE:

There are no user serviceable parts inside your device. Attempting to repair or service your unit may void your warranty:

1.2 Safety Warnings and IEC Symbols

This device is marked with international safety and hazard symbols in accordance with IEC standards. It is important to read and follow all precautions and instructions in this manual before operating or commissioning this device as it contains important information relating to safety and EMC. Failure to follow all safety precautions may result in injury and or damage to your device. Use of this device in a manner not specified will void your warranty

IEC symbols



documentation



Description

Caution, refer to accompanying

EU's Waste Electrical and Electronic
Equipment Compliance

Figure 1-1. IEC Symbols

1.3 Statement on Marking

1.4.1 Marking

It is the policy of OMEGA to comply with all worldwide safety and EMI/EMC regulations that apply. OMEGA is constantly pursuing certification of its products to the European New Approach Directives. OMEGA will add the mark to every appropriate device upon certification.

1.4 General Description

1.4.1 General Description

TJ-USB: Type-K Thermocouple probes with direct USB connection features a rugged transition joint construction.

RH-USB: Relative Humidity/Temperature Probe with direct USB connection features a rugged Stainless Steel Housing.

UTC-USB: Patented Universal Thermocouple Connector/Converter with USB output.

PX409-USB: Pressure Transducer with direct USB connection, features a micro-machined silicon sensor and 316L stainless steel wetted parts.

IR-USB: Infrared temperature sensor with direct USB connection.

1.4.2 Overall Dimensions

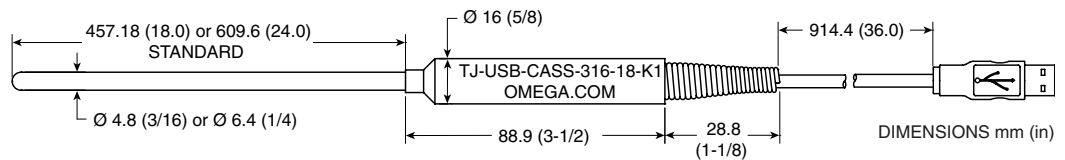

Figure 1-2. TJ-USB Overall Dimensions

All models feature an integral 2m (6') shielded output cable and free user software that converts your PC into a humidity, or temperature or pressure strip chart data logger.

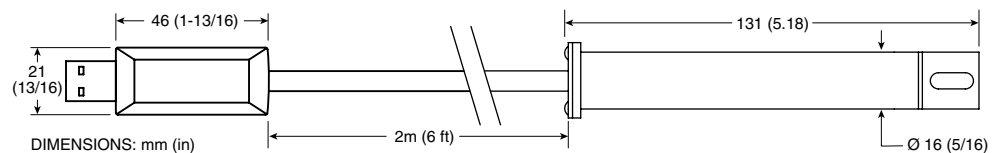

Figure 1-3. RH-USB Dimensions

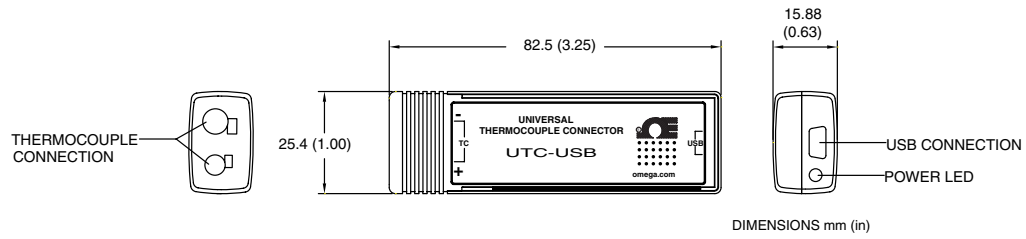

Figure 1-4. UTC-USB Dimensions

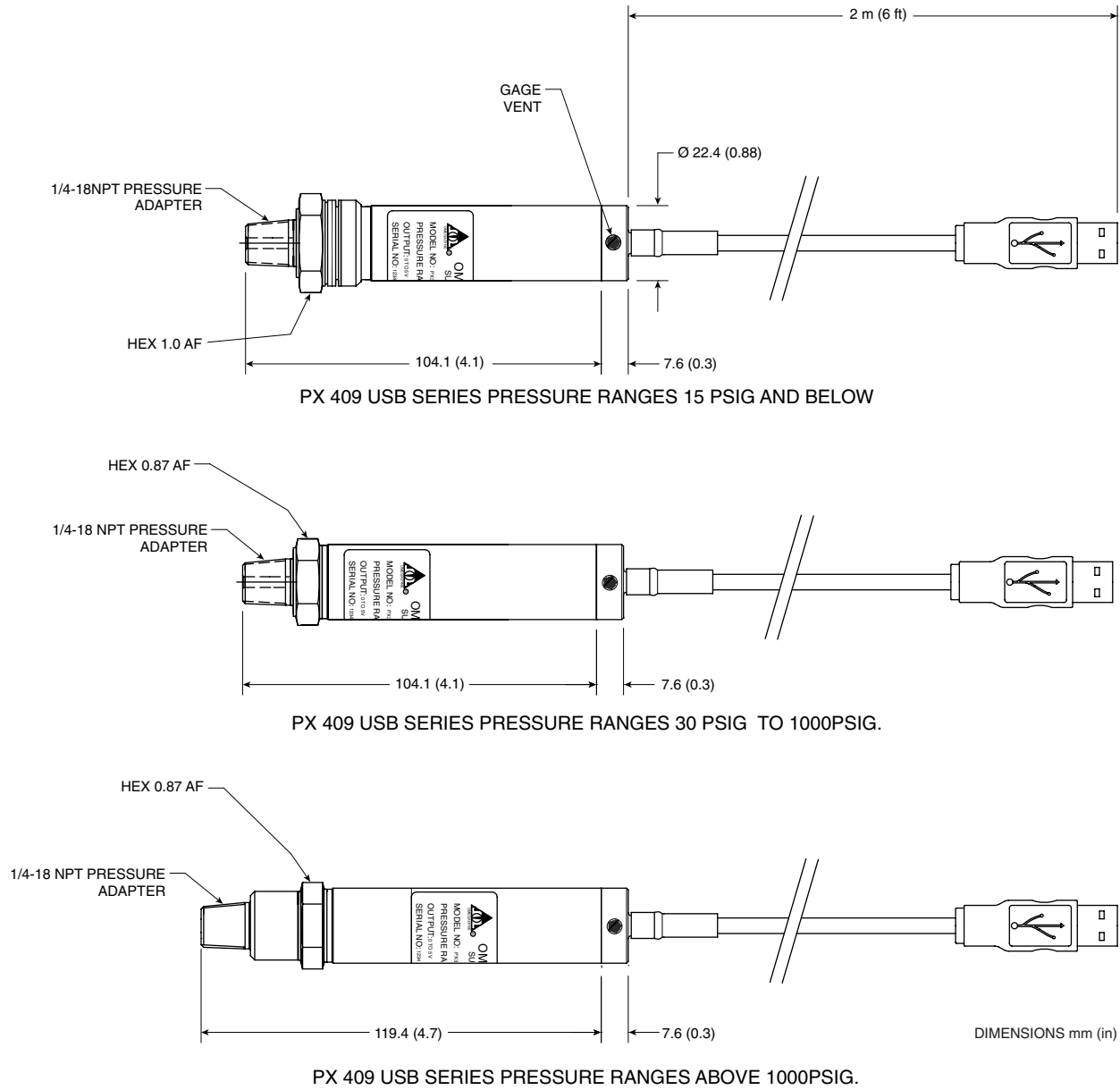

Figure 1-5. PX409-USB Overall Dimensions

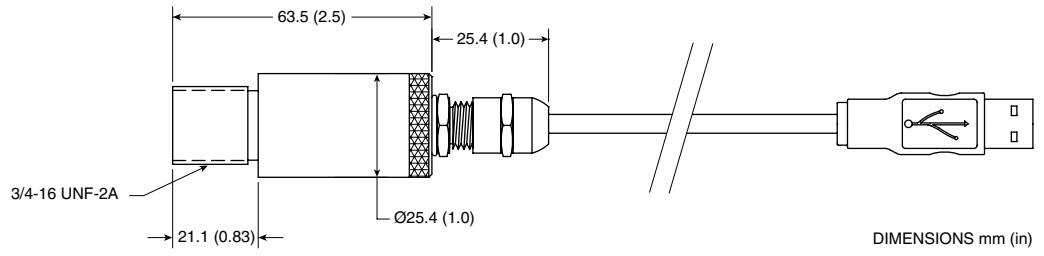

Figure 1-6. IR-USB Dimensions

Section 2 – Hardware

It is important that you read this manual completely and follow all safety precautions before operating this instrument.

2.1 Package Inspection

Remove the packing list and verify that you have received all your equipment. If you have any questions about the shipment, please call our Customer Service Department at 1-800-622-2378 or 203-359-1660. We can also be reached on the Internet at www.omega.com, e-mail: cservice@omega.com

When you receive the shipment, inspect the container and equipment for any signs of damage. Note any evidence of rough handling in transit. Immediately report any damage to the shipping agent.

NOTE:

The carrier will not honor any damage claims unless all shipping material is saved for inspection. After examining and removing contents, save packing material and carton in the event reshipment is necessary.

2.2 Included Items

The following items are supplied in the box.

- 1 TJ-USB Probe Assembly, or 1 RH-USB Probe Assembly, or 1 UTC-USB Universal Thermocouple Connector, PX409-USB Pressure Transducer Assembly, or IR-USB Infrared Temperature Sensor
- 1 USB cable 6' Long (Model UTC-USB Only)
- Software and manual are downloadable from omega.com

2.3 IR-USB Accessories

The IR-USB is offered with four different accessories:

- **Mounting Bracket:** for wall mounting of the sensor
- **Air Purge Collar:** used to keep the surface of the optical clean and safe from smoke, dust, and fumes
- **Water Cooling Jacket:** for operating in an ambient temperature above 85°C (185°F), for temperatures up to 200°C (392°F)
- **Laser Sighting Accessory:** for alignment of the sensor head to the target area to make a more precise reading (see Section 2.3.2 for more information)

2.3.1 IR-USB Accessories Dimensions

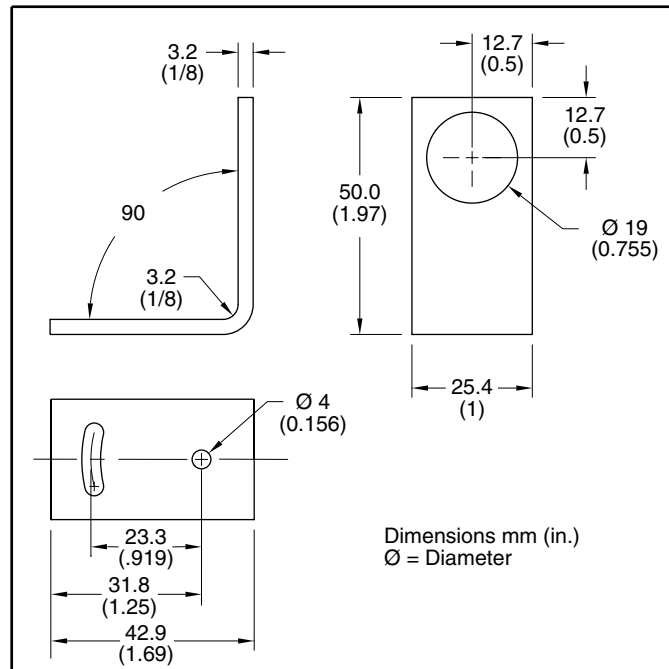

Figure 2-1. Mounting Bracket, OS100-MB

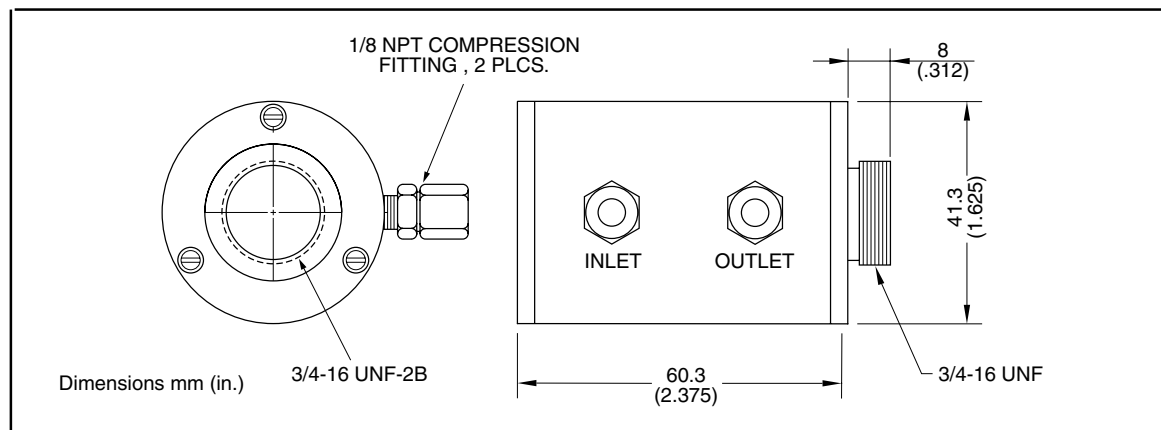

Figure 2-2. Water Cooling Jacket, OS100-WC

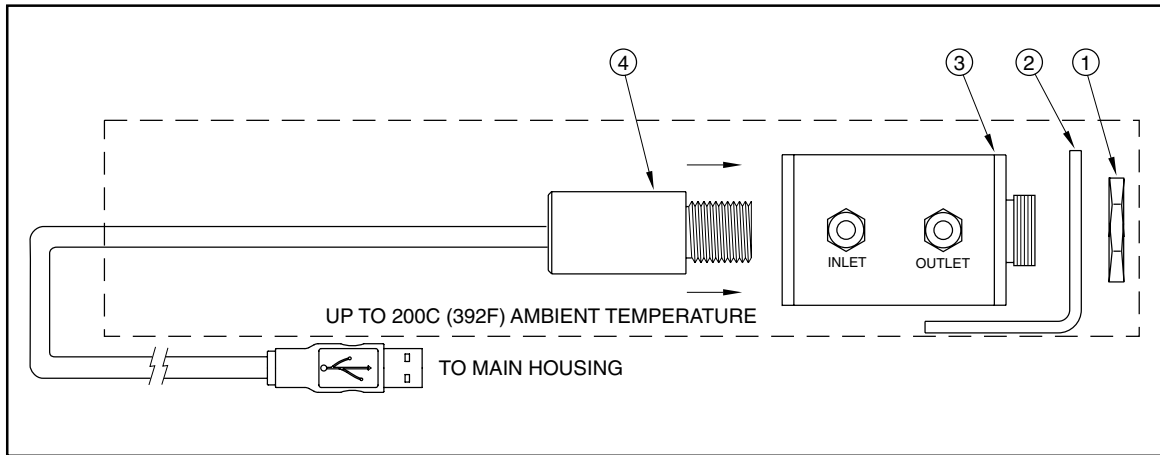

Figure 2-3. Typical Water Cool Jacket Assembly

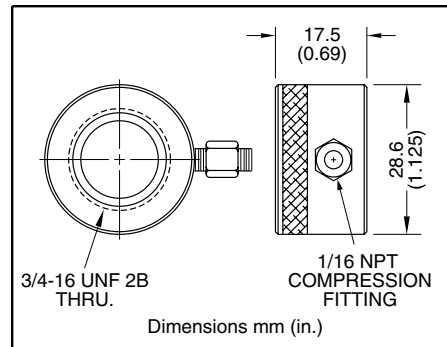

Figure 2-4. Air Purge Collar, OS100-AP

2.3.2 Laser Sighting Accessory Operation

The laser sight accessory screws onto the front of the sensor head. This accessory is only used for alignment of the sensor head to the target area. After the alignment process, the accessory has to be removed from the front of the sensor head before temperature measurement.

The laser sight accessory is powered from a small compact battery pack (included with the accessory). Connect the battery pack to the accessory using the cable provided. Aim at the target, and turn on the battery power using the slide switch on the battery pack. Adjust the sensor head position so that the laser beam points to the center of the target area. Turn off the battery pack, and remove the laser sighting accessory from the sensor head. See Fig. 2-5 for reference.

CAUTION:

You may receive harmful laser radiation exposure if you do not adhere to the warnings listed below:

- **Use of controls or adjustments or performance of procedures other than those specified here may result in hazardous radiation exposure.**
- **Do not look at the laser beam coming out of the lens or view directly with optical instruments - eye damage can result.**
- **Use extreme caution when operation the laser sight accessory**
- **Never point the laser accessory at a person**
- **Keep out of the reach of all children**

WARNING:

Do not attempt to open the laser sight accessory. There are no user serviceable parts inside.

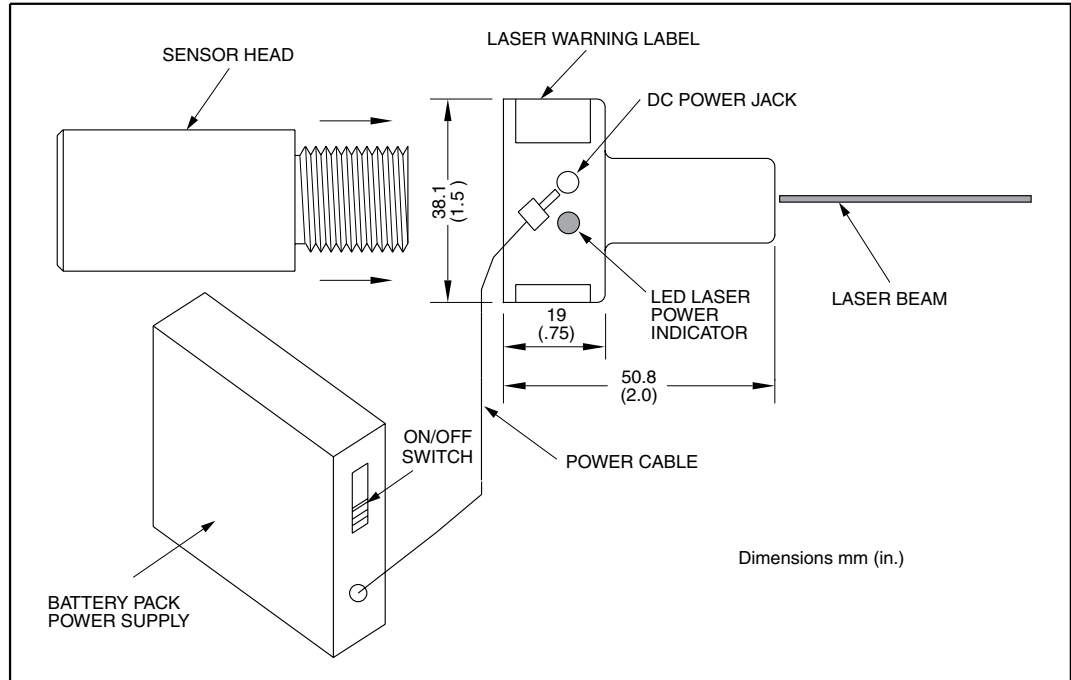



Figure 2-5. Laser Sighting Accessory, OS100-LS



LASER RADIATION DO NOT STARE INTO BEAM OR VIEW DIRECTLY WITH OPTICAL INSTRUMENTS. CLASS 2 LASER PRODUCT.



OMEGA[®]
CAUTION

AVOID EXPOSURE. LASER RADIATION IS EMITTED FROM THIS APERTURE.



LASER RADIATION - DO NOT STARE INTO BEAM

OUTPUT <1 mW, WAVELENGTH 630-670 nm, CLASS II (2) LASER PRODUCT. COMPLIES WITH FDA 21CFR 1040.10 & EN60825-1/11.2001



Figure 2-6. Laser Warning Label

Section 3 – Software

3.1 Getting Started

The following program files are included on the TRH Central User Software CD supplied with your unit. These files can be downloaded from the omega.com website should you misplace your CD.

- TRH Central Measurement and Data Logging Program
- TRH Central Series Manual (pdf format)

3.2 Software Installation Requirements

3.2.1 System Requirements

Your PC should meet the following minimum requirements:

- Pentium Class or higher processor
- Hard Drive Space: 30 meg
- Ram: 256 meg
- 1 Available USB Port
- 1 CD-ROM Drive
- Windows® XP, Vista (32bit or 64bit), or Windows 7 (32bit or 64bit) Operating System

3.3 Software Installation

Insert the TRH-Central User CD that was included with your unit into the CD-ROM drive on your PC. Your system should begin the installation process automatically.

This welcome screen should be visible on your computer screen. To continue with installing the program click the “Next >” button.



This “Install Options” screen should be visible on your computer. To continue with installing the program check both boxes shown and click the “Next >” button.

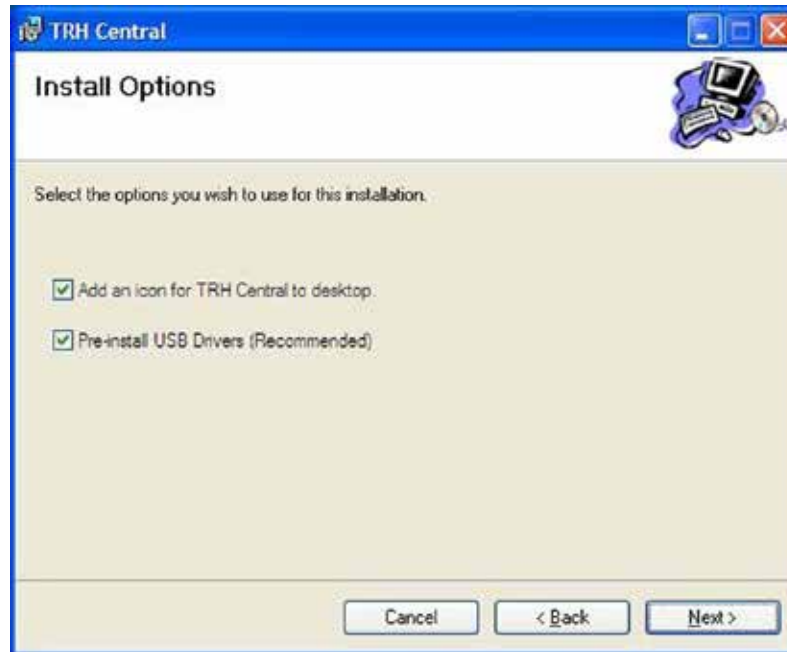

Figure 3-2. Install Options Screen

From this screen you select the folder where you want the program files installed on your PC. The default setting will install the software under your “Program” folders in a new folder named “Omega” To continue with



installing the program click the “Next >” button.

Figure 3-3. Select Install Folder Screen

From this screen you must select “Agree” to continue installing your program. After making your selection click the “Next >” button. The setup wizard will now install the software.



Figure 3-4. License Agreement Screen

The setup wizard now has all the information to complete the installation of the software on your PC. To continue with installing the program click the “Next >” button.

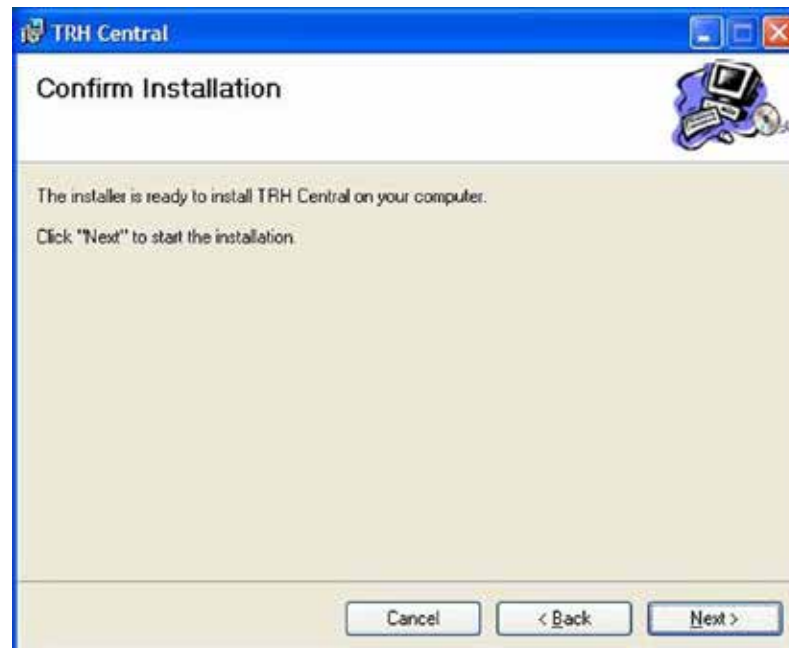

Figure 3-5. Confirm Installation Screen

The setup wizard will now install the proper drivers. To continue with installing the program click the “Next >” button.



Figure 3-6. Welcome to the Device Driver Installation Wizard Screen
Driver installation begins

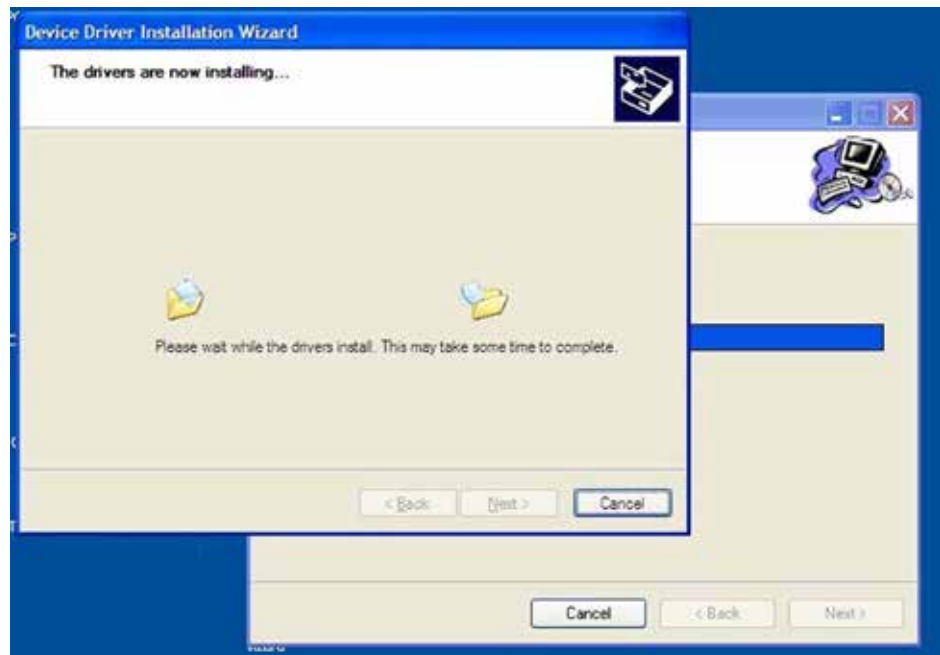

Figure 3-7. Device Driver Installation Wizard Screen

After the installation wizard completes the driver process you should see the screen below. To finish click the “Finish >” button.

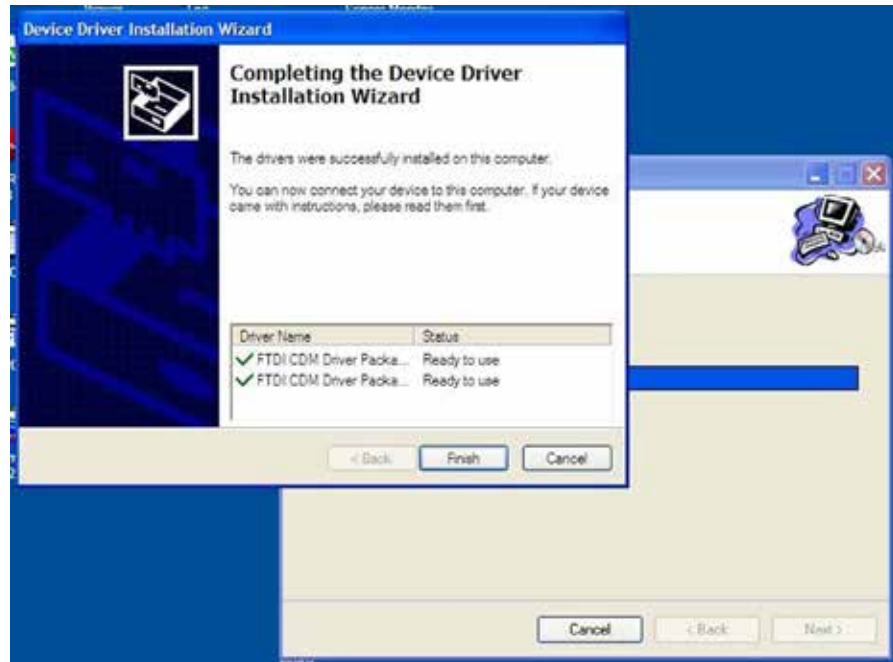

Figure 3-8. Completing the Device Driver Installation Wizard Screen

Congratulations! You have just successfully installed the TRH Central Program on your PC. To end installing the program and close the setup wizard click the “Close” button.

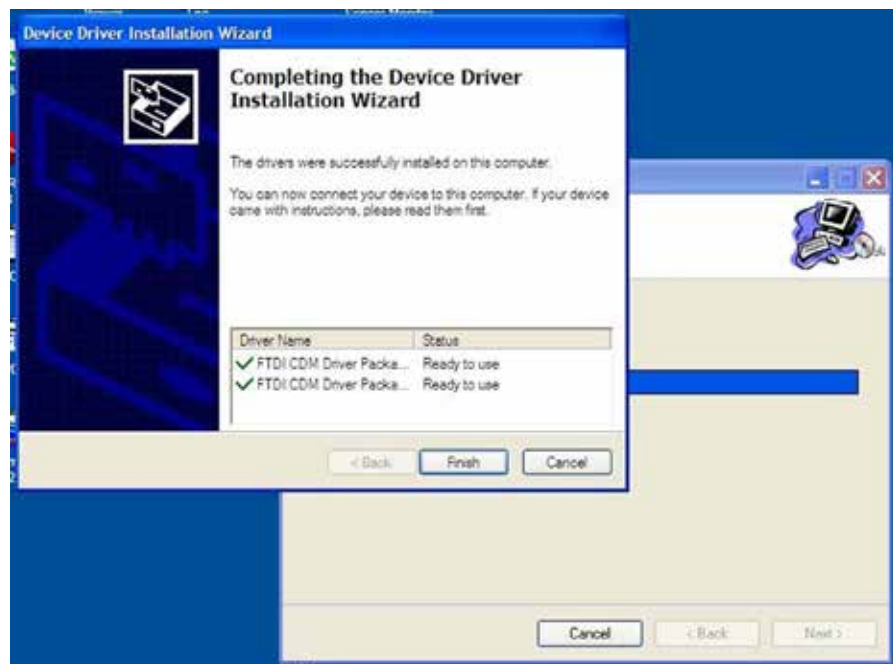

Figure 3-9. Installation Complete Screen

3.4 TRH Central Measurement and Recording Program

To launch the TRH Central program on your PC begin by accessing the “All Programs” list under your “Start Menu” Next, scroll through the list of program folders to find the “Omega” folder. Inside the “Omega” folder click on the “TRH Central” program link. This will start the software running.

3.4.1 Main Tab Menu

Channels Tab

The “Channels” tab shown below is the default screen that is displayed when you run the program. This screen provides a real-time digital reading of relative humidity (when used with model RH-USB) or pressure in PSI (when used with model PX409-USB) or temperature (when used with model TJ-USB, UTC-USB, or IR-USB) in either °F or °C. You can change from °F to °C by clicking with your pointer the on screen °F or °C buttons.



Figure 3-10. Channel Tab Screen

This is a partial view below of the TRH Central Program in operation. This shows one RH-USB Probe on Channel #1 one TJ-USB Probe on Channel #2, and one PX409-USB Probe on channel #3, being used at the same time.

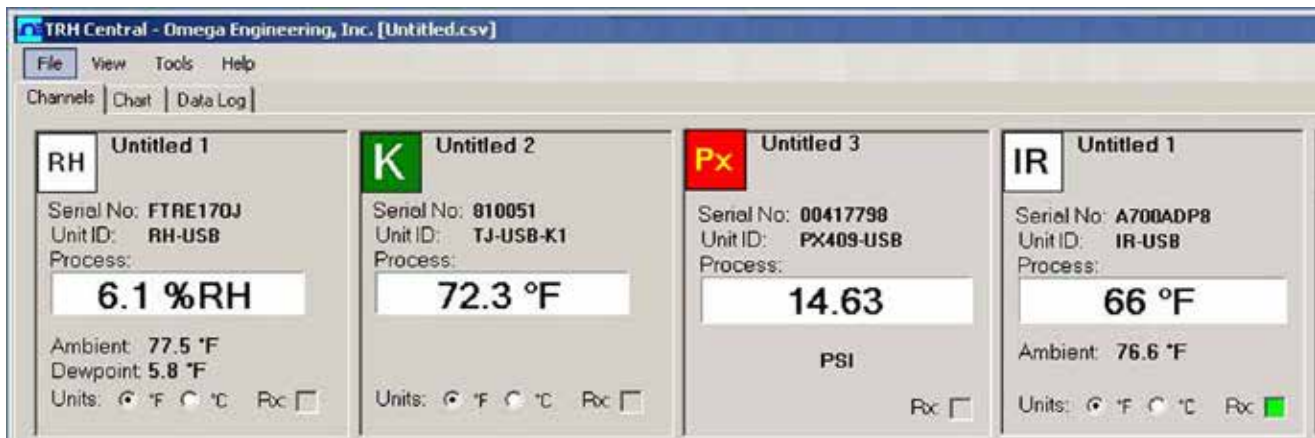

Figure 3-11. TRH Central Program Screen

3.4.2 Channel Configuration

From the “Tools” pull-down menu select “Configure”...“Channel 1”. This will open the program settings table where you can make selections on how you want your system to operate.

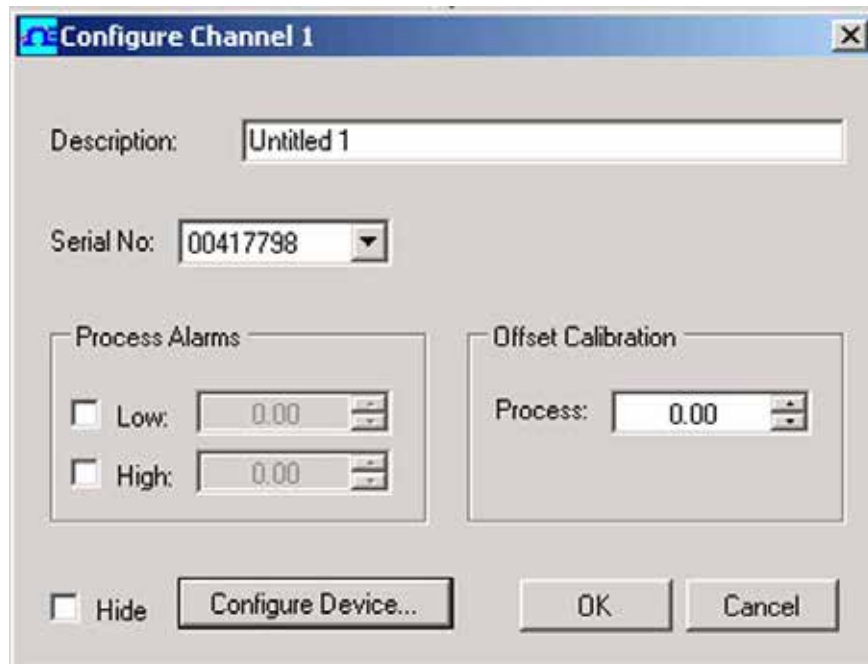

Figure 3-12. Channel Configuration Screen

Description Field

In the Description Field you can type a reference name that is associated with the location or process being measured by the USB device. Example.. “Test Chamber 1”

Low Alarm/High Alarm

When the “High” or “Low” Alarm box is checked the alarm feature becomes active. Click with your mouse on the “Up” and “Down” buttons to advance to a higher or lower setting. The displayed temperature reading will change to RED digits and begin blinking to indicate that the process temperature has gone below the low alarm or exceeded the high alarm value.

Offset Calibration

This allows you to enter a positive or negative offset to both the process and ambient readings if needed.

Hide

When the “Hide” box is checked the particular box that you are configuring will become inactive and will not show up on the screen when running the TRH Central program. This is used to remove unused boxes when less than 12 units are being used.

Configure Device

This button opens the dialog box shown on next page (Fig. 3-13).

This box allows you to adjust filter settings to obtain the best balance between response time and reading stability.

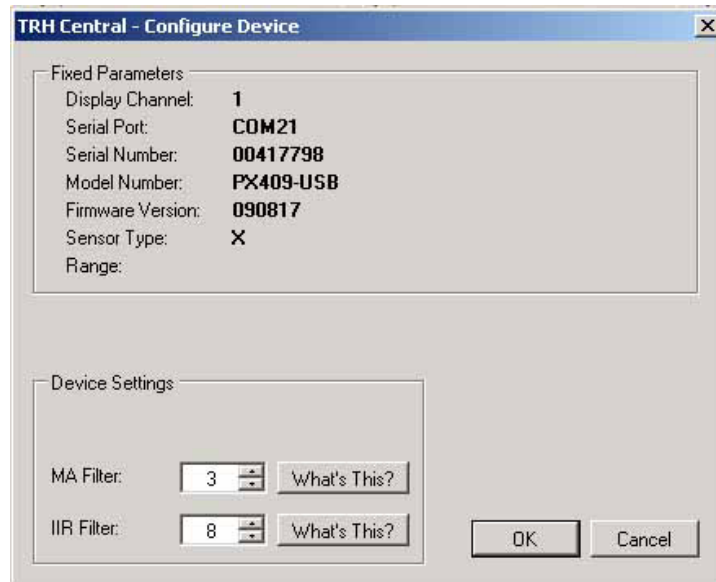

Figure 3-13. Device Configuration Screen

3.5 Chart Tab

The “Chart” tab allows you to start, stop and view real-time data from the transmitters in a screen plot that you can save and print.

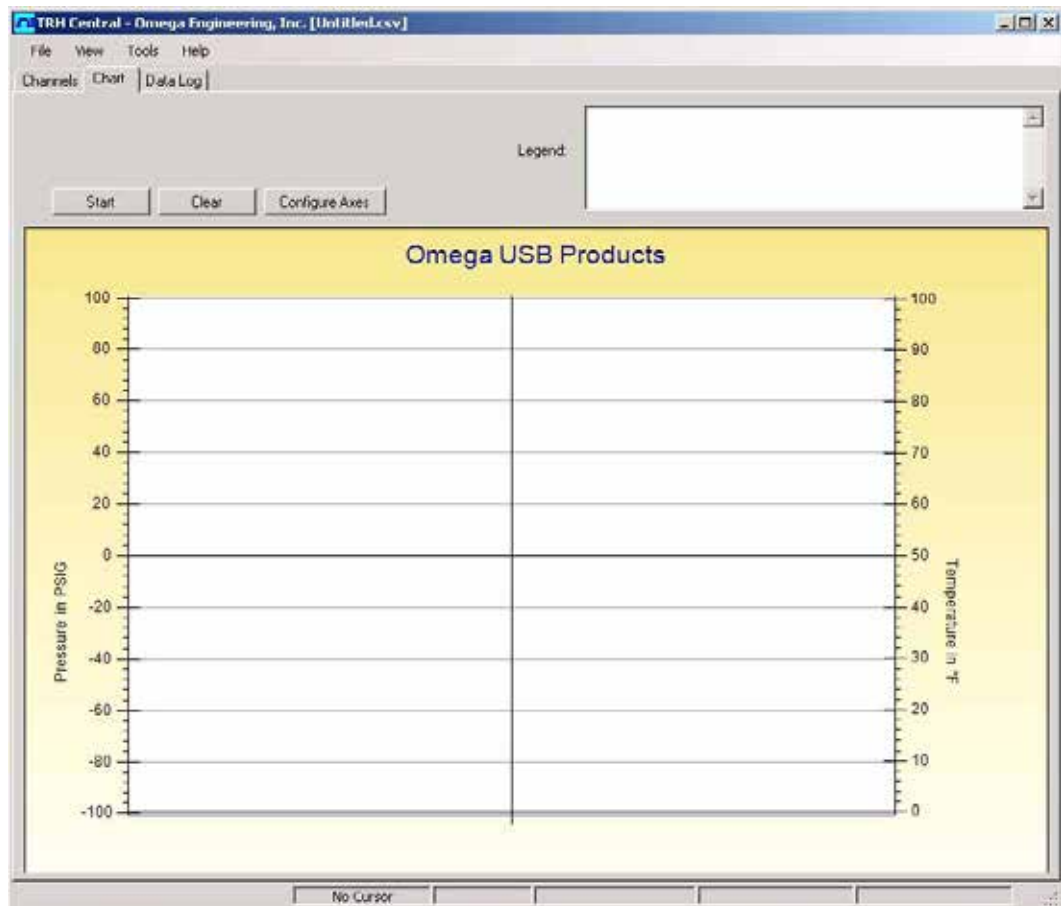

Figure 3-14. Charting Screen

Start Button

The “Start” button will open the dialog box shown below. This box allows you to select one or more channels to be plotted. Click the checkbox next to the channel(s) number you want to include in your plot.

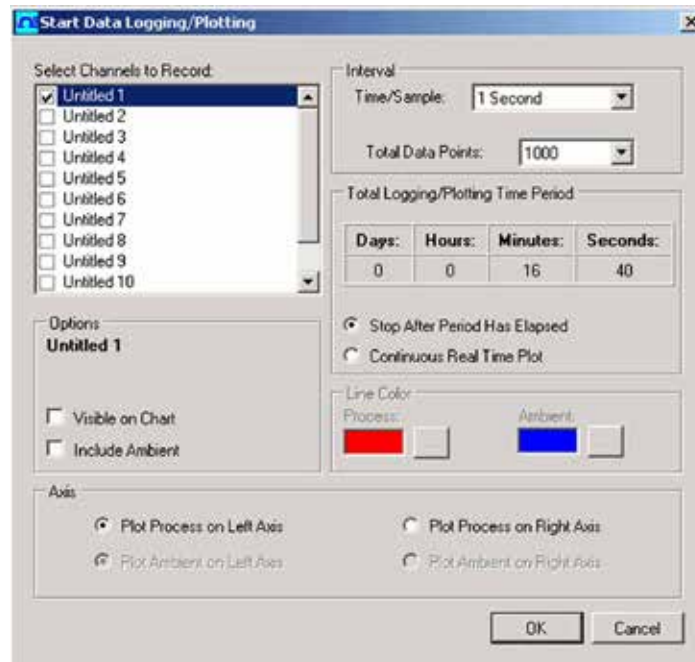

Figure 3-15. Start Data Logging/ Plotting Screen

Line Color

You can change the color specified for each channel’s line. Click the “Change” button to select a new color for the Channel selected.

Interval

The total logging time is displayed for the interval setting selected. In general, the interval should normally be set to a value equal to or greater than the same sample time you programmed into the corresponding connector/ transmitter for that channel.

You can choose to have the data logging/chart recording session end after 1000 data points, or have the session run continuously. After 1000 data points have been collected in the continuous mode, the oldest data point is shifted out on the left, and the newest data point is added to the right. Data will continue to be collected and displayed until you click on the “Stop” button above the chart. If you click the OK button, the data logging session will start, and “Recording Data” will flash in the status bar. The “Start” button above the chart will change to “Stop”, indicating that if you click it again, the logging session will be terminated.

You can also start or stop a data recording session from the File menu. Once data has been collected, you can save it in a (*.csv) (comma separated values) file and open it in Microsoft Excel for further analysis. It is recommended that you “Save As” in Excel as a Microsoft Excel Workbook (*.xls). If you do not modify the (*.csv) version of the file, you can open it from TRH Central’s File menu, and display it in the chart and data log.

Clear Button

The “Clear” button will delete all data from the chart and the data log.

Configure Axis Button

The “Configure Axis” button allows you to configure both the left and right Y axis on your chart. The Y Axis Min and Y Axis Max controls allow you to adjust the viewable range of values to suit your particular application. The narrower the range between min and max, the more detail can be seen on the chart.

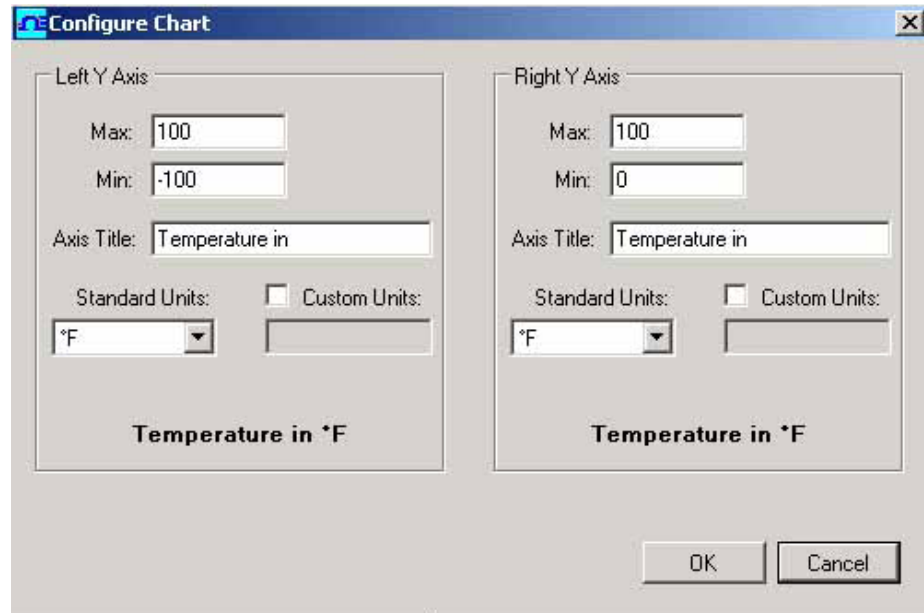

Figure 3-16. Configure Axis Screen

C or F Button

The C or F button allows you to change the units of degrees displayed on the chart, and on the data logging.

3.6 Charting Options

You can access all of the charting options that are available by opening the

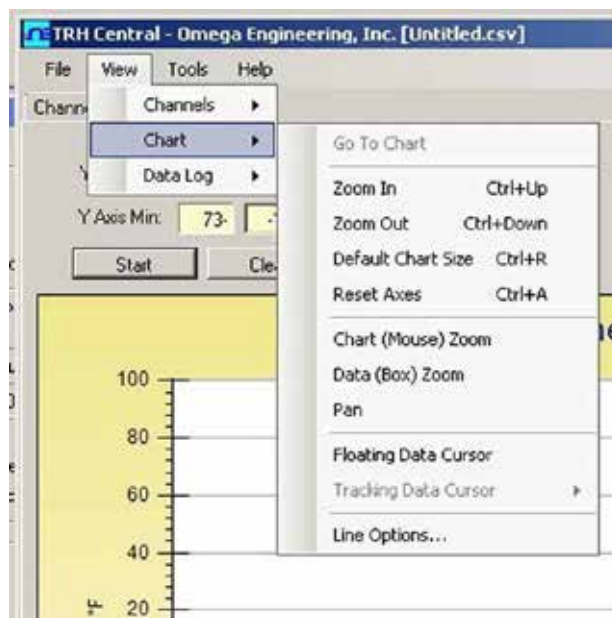

chart option menu found under the “View” Tab. See below.

Figure 3-17. Charting Options Screen

Zoom In/Zoom Out

Allow you to change the size of the chart on the screen. You can also use the Control-Up Arrow and Control-Down Arrow keys as well.

Default Chart Size

Returns the chart to its normal size (after zooming or panning), and places the title and legend in their normal positions.

Reset Axes

Reset Axes will effectively cancel the results of a Data Zoom and return the axes back to their original dimensions, but will not change the size of the chart.

Chart (Mouse) Zoom

Perform the same function as mentioned above, by moving the mouse up or down, or rolling the mouse wheel.

Data (Box) Zoom

When checked, you can use the mouse to click and drag a rectangle around a line of data to magnify that portion of the chart. The chart size will remain the same, but the axes will be expanded as well and the data line(s) to allow viewing more detail. You can close either of the axis scroll bars by clicking on the Red button of each scroll bar.

Pan

Allows you to move the chart as well as the title and legend around on the screen. If the Pan item is checked, you can still use the mouse wheel to zoom in and out, while holding the left button down to move the chart as

Reset Axes will effectively cancel the results of a Data Zoom and return the axes back to their original dimensions, but will not change the size of the chart.

Floating Cursor

When checked, will display a crosshair type cursor that you can move with the mouse. You can use the Floating Cursor to pinpoint a particular temperature and time. The status bar displays the data point number, the time, and the temperature, where the crosshairs meet. If the horizontal cursor line is touching a data plot line, the corresponding channel number is also displayed in the status bar.

Tracking Cursor

When checked, will perform similarly to the Floating Cursor, except that you can specify a channel for the horizontal cursor line to lock on to. This channel is also displayed in the status bar. With this option enabled, you can move the mouse left and right without regard to up and down, and the horizontal cursor will remain pointing to the line (channel) you specify. Assuming you have more than one channel plotted on the chart, you can switch tracking to another channel by moving the mouse over the data line of that channel until the mouse cursor becomes a hand with a pointing finger. If you left-click at this point, the Tracking Cursor will track that line. You can also change the channel of the Tracking Cursor from the chart's context menu, Tracking Cursor menu item combo box. The same option is also available in the View Chart menu in the main menu bar

Line Options

Allows you to select which channel(s) you want to display, and/or change the color of each channel data line. This allows you to limit your view to either a single channel, or a selected two or more channels for comparison, instead of having all twelve channels displayed at once.

3.6 Data Log Tab

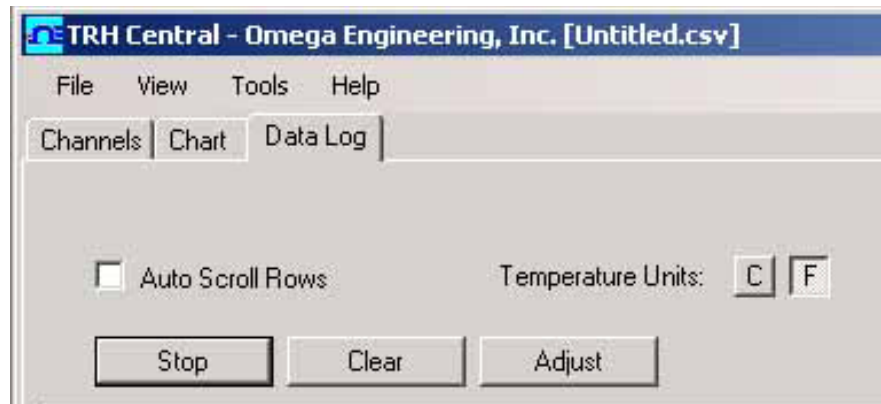

Figure 3-18. Data Log TAB Screen

Data Log Tab

The "Data Log" tab allows you to view received data in a table format of any data as it is being recorded, or data retrieved from a file. The Start and Clear button perform the same function as the Start and Clear buttons on the Chart Tab. See Chart Tab above. The adjust button resizes the columns to the smallest size necessary to fit the data in the columns. You can also change the engineering units of the data from C to F using the C/F buttons. The Auto Scroll Rows checkbox causes the data to be scrolled up one line each time a new row of data is added to the grid.

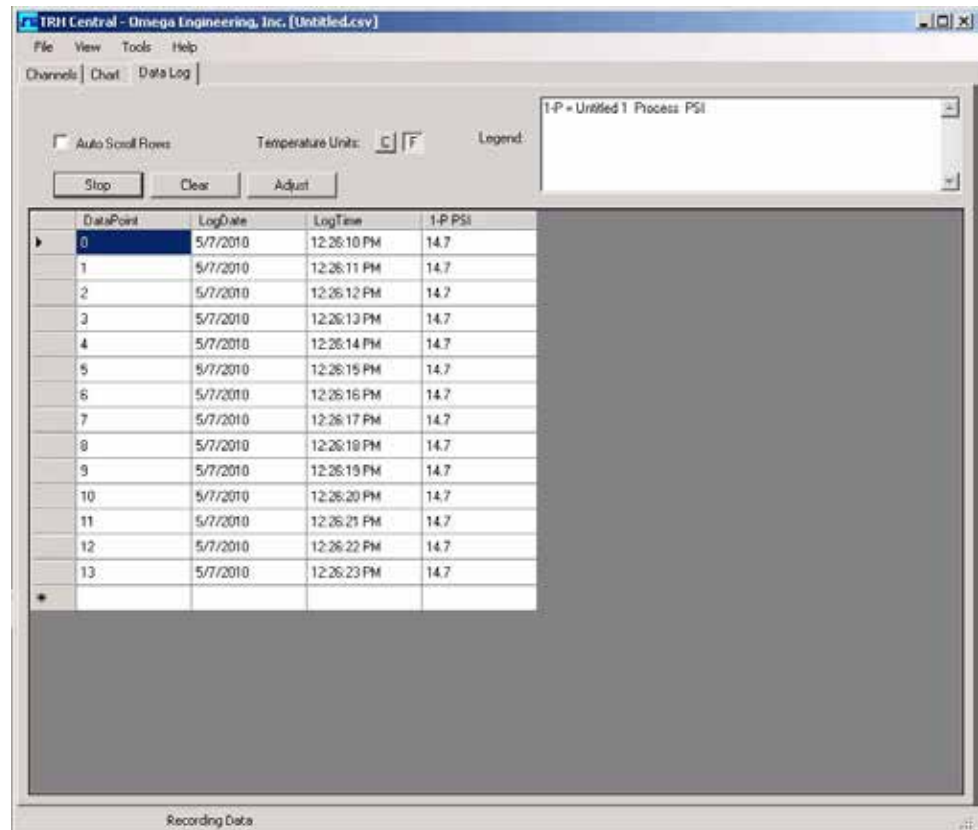

Figure 3-19. Data Logging Screen

Start Button

The “Start” button will open the dialog box shown below. This box allows you to select one or more channels to be plotted. Click the checkbox next to the channel(s) number you want to include in your plot.

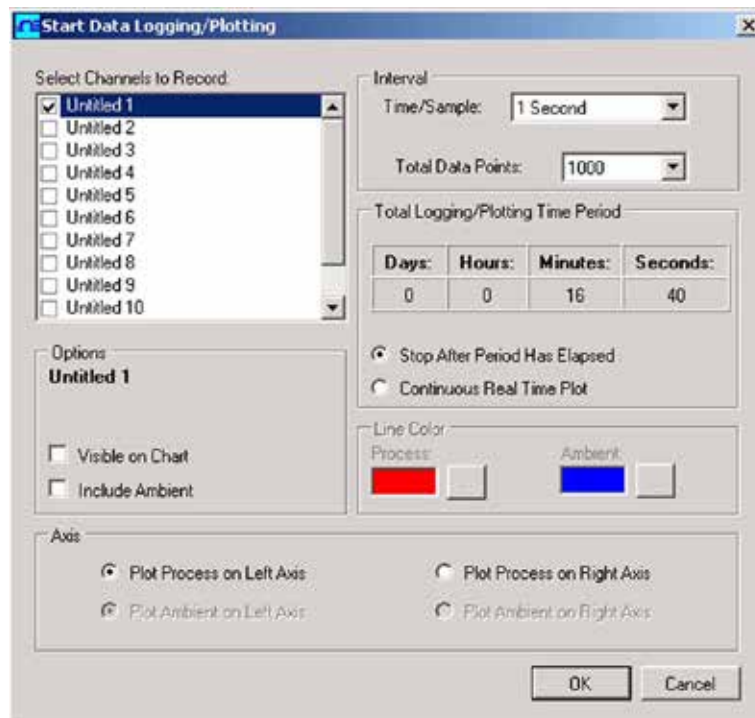

Figure 3-20. Start Data Logging/Plotting Screen

Menus

File Menu

The Open menu item displays a dialog box which allows you to choose a data file to open and display on the graph and in the data log. This file must be a file that was saved by the Save menu item in TRH Central. If the file has been modified externally, you may not be able to open it.

The Save menu item displays a dialog box which allows you to save the data currently displayed on the graph and in the data log. The file format is (*.csv) (comma separated values), which can be opened by Microsoft Excel for further analysis and charting. It is strongly recommended that you do not modify this file, or you may not be able to open it again in USB-Temp. Use Excel's "Save As" option to save it as a Microsoft Excel Workbook (*.xls), which you can then modify.

The Export Graph menu item displays a dialog box that allows you to either save an image of the current graph on the Graph Tab, or copy it to the clipboard.

The Print Preview menu item displays a standard Windows Print Preview dialog, allowing you to view the item(s) as they would be printed on a printer. You can also print from this dialog by clicking the printer icon in the upper left corner. If the Graph Tab is displayed before choosing this option, the current graph image will be previewed. If the Data Acquisition Tab is displayed, the data table in grid style format will be previewed.

The Print menu item displays a standard Windows Print dialog box. This allows you to select printers, printer preferences, page ranges, number of copies, etc. If you click the "Print" button, the specified page(s) will be sent to the printer. If you click the "Apply" button, you can then select the Print Preview menu to view your changes without printing.

The Exit menu option exits the TRH Central program.

View Menu

The Show Toolbar menu allows you to display an optional toolbar for file open, save, print, and graph positioning.

The Show Most Recently Used menu option displays the most recently used (opened/saved) filenames in the File menu.

The Clear Most Recently Used menu option removes all recently used filenames from the File menu.

Graph Menu

Graph Tools Cursor

Floating Cursor, when checked, will display a crosshair type cursor that you can move with the mouse. You can use the Floating Cursor to pinpoint a particular temperature and time. The status bar displays the data point number, the time, and the temperature, where the crosshairs meet.

Tracking Cursor, when checked, will perform similarly to the Floating Cursor, except that it will lock on to the plot line. With this option enabled, you can move the mouse left and right without regard to up and down, and the horizontal cursor will remain pointing to the plot line.

Data (Box) Zoom, when checked, allows you to use the mouse to click and drag a rectangle around a line of data to magnify that portion of the chart. The chart size will remain the same, but the axes will be expanded as well and the data line(s) to allow viewing more detail. Click and drag the left mouse button to the right and downwards. A bluish translucent rectangle will appear showing the area that will be displayed when the mouse button is released. Note that moving the mouse in the opposite direction Zooms Out. To cancel data zoom select "Reset Axes" from either the context menu or Graph menu options.

Zoom allows you to change the overall zoom factor of the chart. This is achieved by clicking the left mouse button anywhere on the chart and dragging the mouse. Dragging the mouse toward the bottom of the chart area zooms out while dragging toward the top zooms in. If you have a wheel mouse you can zoom in/out by clicking on the chart then use the wheel to zoom in/out.

Configure

The Configure Axes menu allows you to adjust the viewable range of temperatures to suit your particular application. The narrower the range between minimum and maximum, the more detail can be seen on the chart.

The Graph Area menu allows you to change the color and/or style of the chart background, lines and markers.

The Show Gridlines option displays or hides gridlines on the graph.

The Show Markers option displays or hides data point markers on the plotted data line.

Cancel Zoom will cancel and uncheck Data (Box Zoom) or Zoom if either is enabled.

Reset Axes returns the graph to its original size.

Data Menu

The Auto Fit Columns menu option resizes the columns to the smallest size necessary to fit all the data in the columns.

The Auto Scroll menu option causes the data to be scrolled up one line each time a new row of data is added to the grid.

Section 4 – Specifications

Model TJ-USB Temperature Probe

Integral Thermocouple:	Type- K (ungrounded)
Measurement Range:	K1: -73 to 315°C (-100 to 600°F) K2: -200 to 1000°C (-354 to 1832°F) NOTE: For 304 stainless steel max temperature is 850°C (1562°F)
Accuracy	
K1:	±1°C (1.8°F)
K2:	±3°C (5.4°F)
Resolution:	USB-TC-K1: 0.1°; USB-TC-K2: 1°
Stability:	USB-TC-K1: ±0.25°C, USB-TC-K2: ±0.5°C
Cold Junction Compensation (Automatic):	-10 to 70°C
Operating Environment:	-10 to 70°C, 0-95% relative humidity (non-condensing)
PC Interface:	USB
USB Cable:	Integral to probe, (6' shielded) Type A.
Software (Included):	Requires Windows® XP, Vista (32bit or 64bit), or Windows 7 (32bit or 64bit) operating system
Weight:	70 g (2.5 oz)

Section 4 – Specifications cont'd.

Model UTC-USB Universal Thermocouple Connector/Converter

User Selectable:

J, K, T, E, R, S, B, C or N Thermocouple Measurement Range:

J:	-100 to 760°C (-148 to 1400°F)
K:	-100 to 1260°C (-148 to 2300°F)
T:	-200 to 400°C (-328 to 752°F)
E:	-200 to 1000°C (-328 to 1832°F)
R:	260 to 1760°C (500 to 3200°F)
S:	260 to 1760°C (500 to 3200°F)
B:	870 to 1820°C (1598 to 3308°F)
C:	0 to 2315°C (32 to 4200°F)
N:	-100 to 1260°C (-148 to 2300°F)

Measurement Accuracy:

Type J, K:	±0.5% of reading or ±1.0°C(1.8°F), whichever is greater
Type T, E, N:	±0.5% of reading or ±2.0°C(3.6°F), whichever is greater
Type R, S, B, C:	±0.5% of full scale

Measurement Resolution: 1°C

Cold Junction Compensation (Automatic):

-10 to 70°C (14 to 158°F)

Thermocouple Connection:

Patented universal female accepts both standard or miniature male connector

Operating Environment:

-10 to 70°C (14 to 158°F)

Computer Interface:

USB (one interface cable included with receiver)

Software (Included Free):

Requires Windows® XP, Vista (32bit or 64bit), or Windows 7 (32bit or 64bit) operating system

Dimensions:

76 L x 25.4 W x 13 H mm (3 x 1 x 0.5")

Enclosure:

Plastic (Glass Filled Nylon)

Section 4 – Specifications cont'd.

Model PX409-USB Pressure Transducer

Accuracy:	0.08% Best Straight Line (linearity, hysteresis and repeatability combined)
Temperature Compensation Over Compensated Range:	Span: 0.5% Zero: 0.5%
Minimum Isolation Between:	Case and Output Terminations: 100 M Ω @ 50 Vdc
Pressure Cycles:	1 million, minimum
Long Term Stability (1-Year):	$\pm 0.1\%$ FS typical
A to D Conversion:	14-Bit
Shock:	50g, 11 ms half sine shock, (under test)
Vibration:	$\pm 20g$ (under test)
Bandwidth:	DC to 100 Hz typical Meets industrial emissions and immunity standard IEC61326 (pending)
Environmental Protection:	IP65 or IP67 depending upon electrical termination
Secondary Containment Vacuum and Pressure:	10 inH ₂ O to 5 psi: to 1000 psi 15 to 1000 psi: to 3000 psi 1500 to 5000 psi: to 15,000 psi
Secondary Containment Absolute Pressure:	5 to 1000 psi: to 6000 psi 1500 to 5000 psi: to 15,000 psi
Wetted Parts:	316L SS
Weight:	200 g (7 oz)
Overpressure Gage Pressure:	10 inH ₂ O: 10 times span 1 psi: 6 times span 2.5 psi to 3500 psi: 4 times span 5000 psi: 15,000 psi max
Overpressure Absolute Pressure:	5 psia: 6 times span 15 psia to 3500 psia: 4 times span 5000 psia: 15000 psi max
Operating Temperature Range:	-40 to 85°C (-40 to 185°F)
Compensated Temperature:	Ranges >5 psi: -29 to 85°C (-20 to 185°F) Ranges ≤ 5 psi: -17 to 85°C (0 to 185°F)
Dimensions:	PX409 USB Ranges up to 1000 PSIG, 4.4 L PX409 USB Ranges above 1000 PSIG, 5.0 L 0.88 Dia.
Enclosure:	3/16 L Stainless Steel

Section 4 – Specifications cont'd.**Model RH-USB Humidity Probe****Temperature****Range:** -17 to 49°C (1 to 120°F)**Accuracy:** ±1°C (±1.8°F)**Relative Humidity****Range:** 2 to 98% RH**Accuracy:** ±3% RH (@ 15 to 90% RH)**Repeatability:** ±1% RH**PC Interface:** USB**USB Cable:** Integral to sensor,
2 m (6') (shielded) Type A plug**Software (Included):** Requires Windows® XP, Vista (32bit or 64bit),
or Windows 7 (32bit or 64bit) operating
system**Housing:** 316 stainless steel**Dimensions:** 138 L x 16 mm D (5.5 x 0.625")**Weight:** 67 g (0.18 lbs)

Section 4 – Specifications cont'd.

Model IR-USB and IR-USB-HT Infrared Sensor

PC Interface:	USB
USB Cable:	Integral to sensor, 2 m (6') shielded Type A plug
Software (Included):	Requires Windows® XP, Vista (32bit or 64bit), or Windows 7 (32bit or 64bit) operating system
Temperature Range:	-18 to 538°C (0 to 1000°F)
Accuracy @ 22°C (72°F) Ambient Temperature and Emissivity of 0.95 or Greater:	±2% rdg or 2.2°C (4°F), whichever is greater
Optical Field of View:	6:1 (distance/spot size)
Repeatability:	±1% rdg
Spectral Response:	5 to 14 microns
Response Time:	100 ms (0 to 63% of final value)
Emissivity Range:	0.1 to 1.00, adjustable
Operating Temperature	
Sensor Head:	0 to 70°C (32 to 158°F)
Sensor Head (-HT Model):	0 to 85°C (32 to 185°F)
Sensor Head with OS100-WC (Water Cooling Jacket):	0 to 200°C (32 to 392°F)
Operating Relative Humidity:	Less than 95% RH, non-condensing
Water Flow Rate (OS100-WC):	0.25 GPM, room temperature
Thermal Shock:	~30 minutes for 25°C (77°F) abrupt ambient temperature change
Warm-Up Period:	3 minutes
Air Flow Rate (OS100-AP):	1 CFM (0.5 L/s) (1 x 2.5")

Section 4 – Specifications cont'd.

Laser Sight Accessory (OS100-LS)

Wavelength (Color):	630 - 670 nm (Red)
Operating Distance (Laser Dot):	Up to 9.1 m (30 ft.)
Max. Output Optical Power:	Less than 1 mW at 22°F ambient temperature.
European Classification:	Class 2, EN60825-1/11.2001
Maximum Operating Current:	45 mA at 3 Vdc
FDA Classification:	Complies with 21 CFR 1040.10, Class II Laser Product
Beam Diameter:	5 mm
Beam Divergence:	< 2 mrad
Operating Temperature:	0 to 50°C (32 to 122°F)
Operating Relative Humidity:	Less than 95% RH, non-condensing
Power Switch:	ON/OFF , Slide switch on the Battery Pack
Power Indicator:	Red LED
Power:	Battery Pack, 3 Vdc (Consists of two 1.5 Vdc AA size Lithium Batteries)
Laser Warning Label:	Located on the head sight circumference
Identification Label:	Located on the head sight circumference
Dimensions:	38 DIA x 50.8 mm L (1.5" DIA x 2" L)

Figure 4-1. Optical Field of View

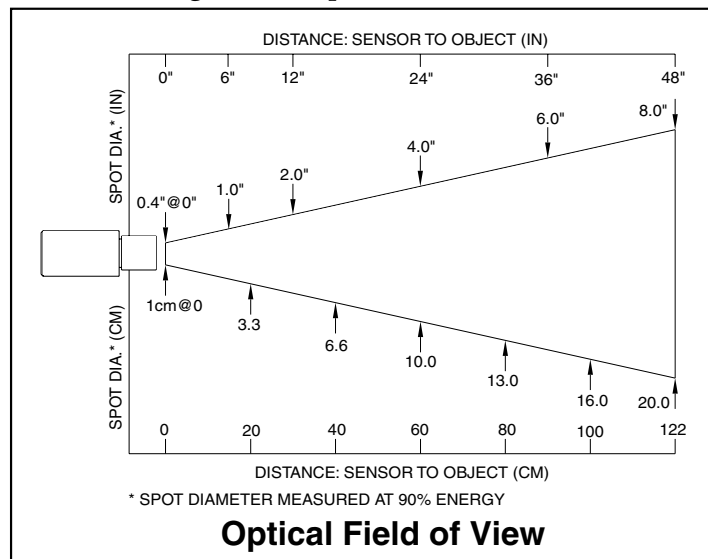

Section 5 - Emissivity Table (For IR-USB Models)

	Material	Emissivity (ϵ)
METALS	<u>Aluminum</u> – pure highly polished plate	0.04 to 0.06
	<u>Aluminum</u> – heavily oxidized	0.20 to 0.31
	<u>Aluminum</u> – commercial sheet	0.09
	<u>Brass</u> – dull plate	0.22
	<u>Brass</u> – highly polished, 73.2% Cu, 26.7% Zn	0.03
	<u>Chromium</u> – polished	0.08 to 0.36
	<u>Copper</u> – polished	0.05
	<u>Copper</u> – heated at 600°C (1112°F)	0.57
	<u>Gold</u> – pure, highly polished or liquid	0.02 to 0.04
	<u>Iron and steel (excluding stainless)</u> – polished iron	0.14 to 0.38
	<u>Iron and steel (excluding stainless)</u> – polished cast iron	0.21
	<u>Iron and steel (excluding stainless)</u> – polished wrought iron	0.28
	<u>Iron and steel (excluding stainless)</u> – oxidized dull wrought iron	0.94
	<u>Iron and steel (excluding stainless)</u> – rusted iron plate	0.69
	<u>Iron and steel (excluding stainless)</u> – polished steel	0.07
	<u>Iron and steel (excluding stainless)</u> – polished steel oxidized at 600°C (1112°F)	0.79
	<u>Iron and steel (excluding stainless)</u> – rolled sheet steel	0.66
	<u>Iron and steel (excluding stainless)</u> – rough steel plate	0.94 to 0.97
	<u>Lead</u> – gray and oxidized	0.28
	<u>Mercury</u>	0.09 to 0.12
	<u>Molybdenum filament</u>	0.10 to 0.20
	<u>Nickel</u> – polished	0.07
	<u>Nickel</u> – oxidized at 649 to 1254°C (1200°F to 2290°F)	0.59 to 0.86
	<u>Platinum</u> – pure polished plate	0.05 to 0.10
	<u>Platinum</u> – wire	0.07 to 0.18
	<u>Silver</u> – pure and polished	0.02 to 0.03
	<u>Stainless steel</u> – polished	0.07
	<u>Stainless steel</u> – Type 301 at 232 to 942°C (450°F to 1725°F)	0.54 to 0.63
<u>Tin</u> – bright	0.06	
<u>Tungsten</u> – filament	0.39	
<u>Zinc</u> – polished commercial pure	0.05	
<u>Zinc</u> – galvanized sheet	0.23	

	Material	Emissivity (ϵ)
NONMETALS	<u>Asbestos Board</u>	0.96
	<u>Asphalt, tar, pitch</u>	0.95 to 1.00
	<u>Brick</u> - red and rough	0.93
	<u>Brick</u> - fireclay	0.75
	<u>Carbon</u> - filament	0.53
	<u>Carbon</u> - lampblack - rough deposit	0.78 to 0.84
	<u>Glass</u> - Pyrex, lead, soda	0.85 to 0.95
	<u>Marble</u> - polished light gray	0.93
	<u>Paints, lacquers, and varnishes</u> - Black matte shellac	0.91
	<u>Paints, lacquers, and varnishes</u> - aluminum paints	0.27 to 0.67
	<u>Paints, lacquers, and varnishes</u> - flat black lacquer	0.96 to 0.98
	<u>Paints, lacquers, and varnishes</u> - white enamel varnish	0.91
	<u>Porcelain</u> - glazed	0.92
	<u>Quartz</u> - opaque	0.68 to 0.92
	<u>Roofing Paper</u>	0.91
	<u>Tape</u> - Masking	0.95
	<u>Water</u>	0.95 to 0.96
<u>Wood</u> - planed oak	0.90	



NOTES:



NOTES:

WARRANTY/DISCLAIMER

OMEGA ENGINEERING, INC. warrants this unit to be free of defects in materials and workmanship for a period of **13 months** from date of purchase. OMEGA's WARRANTY adds an additional one (1) month grace period to the normal **one (1) year product warranty** to cover handling and shipping time. This ensures that OMEGA's customers receive maximum coverage on each product.

If the unit malfunctions, it must be returned to the factory for evaluation. OMEGA's Customer Service Department will issue an Authorized Return (AR) number immediately upon phone or written request. Upon examination by OMEGA, if the unit is found to be defective, it will be repaired or replaced at no charge. OMEGA's WARRANTY does not apply to defects resulting from any action of the purchaser, including but not limited to mishandling, improper interfacing, operation outside of design limits, improper repair, or unauthorized modification. This WARRANTY is VOID if the unit shows evidence of having been tampered with or shows evidence of having been damaged as a result of excessive corrosion; or current, heat, moisture or vibration; improper specification; misapplication; misuse or other operating conditions outside of OMEGA's control. Components in which wear is not warranted, include but are not limited to contact points, fuses, and triacs.

OMEGA is pleased to offer suggestions on the use of its various products. However, OMEGA neither assumes responsibility for any omissions or errors nor assumes liability for any damages that result from the use of its products in accordance with information provided by OMEGA, either verbal or written. OMEGA warrants only that the parts manufactured by the company will be as specified and free of defects. OMEGA MAKES NO OTHER WARRANTIES OR REPRESENTATIONS OF ANY KIND WHATSOEVER, EXPRESSED OR IMPLIED, EXCEPT THAT OF TITLE, AND ALL IMPLIED WARRANTIES INCLUDING ANY WARRANTY OF MERCHANTABILITY AND FITNESS FOR A PARTICULAR PURPOSE ARE HEREBY DISCLAIMED. LIMITATION OF LIABILITY: The remedies of purchaser set forth herein are exclusive, and the total liability of OMEGA with respect to this order, whether based on contract, warranty, negligence, indemnification, strict liability or otherwise, shall not exceed the purchase price of the component upon which liability is based. In no event shall OMEGA be liable for consequential, incidental or special damages.

CONDITIONS: Equipment sold by OMEGA is not intended to be used, nor shall it be used: (1) as a "Basic Component" under 10 CFR 21 (NRC), used in or with any nuclear installation or activity; or (2) in medical applications or used on humans. Should any Product(s) be used in or with any nuclear installation or activity, medical application, used on humans, or misused in any way, OMEGA assumes no responsibility as set forth in our basic WARRANTY/DISCLAIMER language, and, additionally, purchaser will indemnify OMEGA and hold OMEGA harmless from any liability or damage whatsoever arising out of the use of the Product(s) in such a manner.

RETURN REQUESTS/INQUIRIES

Direct all warranty and repair requests/inquiries to the OMEGA Customer Service Department. BEFORE RETURNING ANY PRODUCT(S) TO OMEGA, PURCHASER MUST OBTAIN AN AUTHORIZED RETURN (AR) NUMBER FROM OMEGA'S CUSTOMER SERVICE DEPARTMENT (IN ORDER TO AVOID PROCESSING DELAYS). The assigned AR number should then be marked on the outside of the return package and on any correspondence.

The purchaser is responsible for shipping charges, freight, insurance and proper packaging to prevent breakage in transit.

FOR **WARRANTY** RETURNS, please have the following information available BEFORE contacting OMEGA:

1. Purchase Order number under which the product was PURCHASED,
2. Model and serial number of the product under warranty, and
3. Repair instructions and/or specific problems relative to the product.

FOR **NON-WARRANTY** REPAIRS, consult OMEGA for current repair charges. Have the following information available BEFORE contacting OMEGA:

1. Purchase Order number to cover the COST of the repair,
2. Model and serial number of the product, and
3. Repair instructions and/or specific problems relative to the product.

OMEGA's policy is to make running changes, not model changes, whenever an improvement is possible. This affords our customers the latest in technology and engineering.

OMEGA is a registered trademark of OMEGA ENGINEERING, INC.

© Copyright 2017 OMEGA ENGINEERING, INC. All rights reserved. This document may not be copied, photocopied, reproduced, translated, or reduced to any electronic medium or machine-readable form, in whole or in part, without the prior written consent of OMEGA ENGINEERING, INC.

Where Do I Find Everything I Need for Process Measurement and Control? **OMEGA...Of Course!** *Shop online at omega.comSM*

TEMPERATURE

- ☑ Thermocouple, RTD & Thermistor Probes, Connectors, Panels & Assemblies
- ☑ Wire: Thermocouple, RTD & Thermistor
- ☑ Calibrators & Ice Point References
- ☑ Recorders, Controllers & Process Monitors
- ☑ Infrared Pyrometers

PRESSURE, STRAIN AND FORCE

- ☑ Transducers & Strain Gages
- ☑ Load Cells & Pressure Gages
- ☑ Displacement Transducers
- ☑ Instrumentation & Accessories

FLOW/LEVEL

- ☑ Rotameters, Gas Mass Flowmeters & Flow Computers
- ☑ Air Velocity Indicators
- ☑ Turbine/Paddlewheel Systems
- ☑ Totalizers & Batch Controllers

pH/CONDUCTIVITY

- ☑ pH Electrodes, Testers & Accessories
- ☑ Benchtop/Laboratory Meters
- ☑ Controllers, Calibrators, Simulators & Pumps
- ☑ Industrial pH & Conductivity Equipment

DATA ACQUISITION

- ☑ Communications-Based Acquisition Systems
- ☑ Data Logging Systems
- ☑ Wireless Sensors, Transmitters, & Receivers
- ☑ Signal Conditioners
- ☑ Data Acquisition Software

HEATERS

- ☑ Heating Cable
- ☑ Cartridge & Strip Heaters
- ☑ Immersion & Band Heaters
- ☑ Flexible Heaters
- ☑ Laboratory Heaters

ENVIRONMENTAL MONITORING AND CONTROL

- ☑ Metering & Control Instrumentation
- ☑ Refractometers
- ☑ Pumps & Tubing
- ☑ Air, Soil & Water Monitors
- ☑ Industrial Water & Wastewater Treatment
- ☑ pH, Conductivity & Dissolved Oxygen Instruments